

ELEGO

PHECDA

User Manual

Manual de instrucciones

Manuel utilisateur

Manuale utente Benutzerhandbuch

Benutzerhandbuch

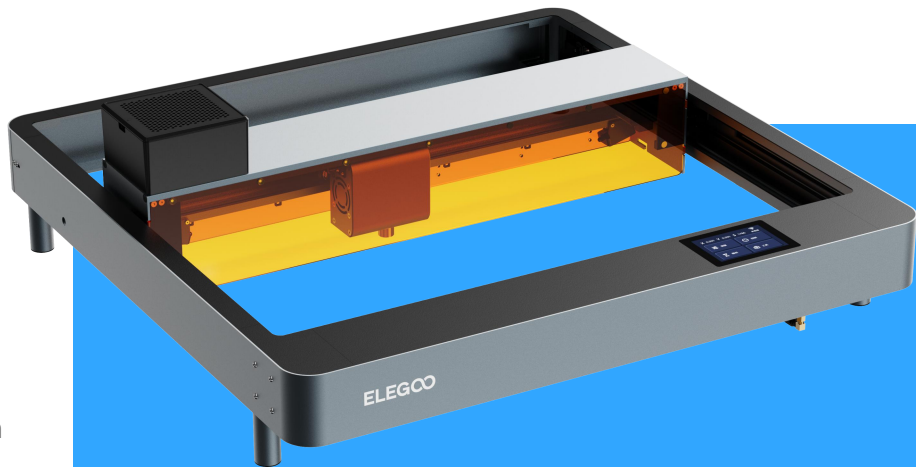

EN	-----	1
ES	-----	21
ITA	-----	43
FR	-----	65
DE	-----	87

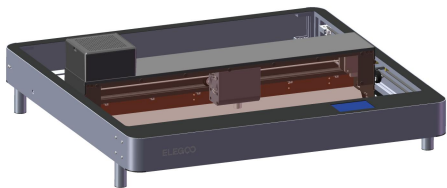

Thank you for choosing ELEGOO product!

For your convenience, please read this instruction manual carefully before use, the cautions and tips in this manual can help you better avoid incorrect installation and use.

For questions or problems not covered in this manual, please contact us at this email: lec@elegoo.com

ELEGOO team is always ready to provide you with quality service.

To give you a better user experience of our products, you can also gain operation knowledge of the equipment in the following ways :

1. The instruction manual: You can find the relevant operating instructions and videos on how to operate the machine in the TF card.
2. ELEGOO official website: www.elegoo.com. You can visit our official website to find the relevant operating instructions for the machine and contact information.

Cautions

1. When the laser engraver starts working, please wear laser goggles to protect your eyes.
2. Please keep the working area of the machine flat and clean. Residues accumulated from cutting and engraving should be cleaned up regularly to prevent fire hazards.
3. Do not engrave or cut any unknown materials, as the vaporization or melting of many materials will release harmful fumes and cause personal injury.
4. Do not operate the machine unattended. If the machine is incorrectly set up to start working and left unattended for a long time, or has a mechanical or electrical failure during operation, it may cause a fire.
5. Please operate the machine in a well-ventilated area so that the machine can exhaust fumes properly.
6. The machine contains high-speed moving parts, so be careful not to pinch your hands.
7. Please do product maintenance frequently, and periodically clean the machine body with a dry cloth to wipe away dust and debris under the situation of power off.
8. Children must be supervised by adults when using the machine to avoid personal injury.
9. In case of an emergency, please turn off the power directly.

Machine Parameters

Machine Model: PHECDA			
PHECDA (10W)		PHECDA (20W)	
Laser head power	10W	Laser head power	20W
Maximum cutting depth	≤8mm (Basswood board)	Maximum cutting depth	≤14mm (Basswood board)
Machine power	55W	Machine power	85W
Rated voltage	100V-240V 50/60Hz	Rated voltage	100V-240V 50/60Hz
Output voltage	24V	Output voltage	24V
Spot size	0.06mm×0.06mm	Spot size	0.07mm×0.13mm
Net weight	6.5kg	Net weight	6.7kg
Printing principle	Laser engraving and cutting	Laser head height adjustment	0-75mm
Engraving area	400mm×400mm	Machine size	673mm×660mm×190mm
Maximum engraving speed	X-axis : 25000mm/min Y-axis : 18000mm/min	Whether to support APP control	Support
Laser wavelength	455±5nm	Expandable functions	rotary attachment, air assist
Auxiliary functions	Smoke filtration, flame detector, tilt detection alarm	Support language	Chinese, English, German, Portuguese, Spanish
Support system	windows/mac/ios/android	Supported file formats	SVG/DXF/JPG/JPEG/PNG/BMP/TIF, etc
Product material	Aluminum alloy	Connection method	TF card, USB cable, APP

Material Settings

- The slower the speed, the greater the engraving power ratio setting, and the deeper the engraving depth. On the contrary, the faster the speed, the more consistent the engraving power, and the shallower the engraving depth.

Engraving material/O	Operation	10W			20W		
		Speed	Times	Power	Speed	Times	Power
Basswood Board(3mm)	cutting	180mm/min	1	55%	300mm/min	1	55%
	engraving	12000mm/min	1	95%	12000mm/min	1	65%
MDF (3mm)	cutting	180mm/min	3	60%	300mm/min	1	100%
	engraving	12000mm/min	1	80%	12000mm/min	1	55%
Bamboo Board(5mm)	cutting	300mm/min	5	100%	180mm/min	1	90%
	engraving	6000mm/min	1	65%	12000mm/min	1	70%
Kraft Paper(150g)	cutting	1800mm/min	1	50%	1800mm/min	1	30%
	engraving	12000mm/min	1	40%	18000mm/min	1	40%
Stainless Steel	cutting	/	/	/	/	/	/
	engraving	2000mm/min	1	100%	2000mm/min	1	50%
Metal business card	cutting	/	/	/	/	/	/
	engraving	6000mm/min	1	40%	6000mm/min	1	25%

The above data are official laboratory tests, and the actual processing process may vary due to differences in materials and environments. The settings based on the test are for reference only and can be adjusted according to the actual situation.

Machine Structure Diagram

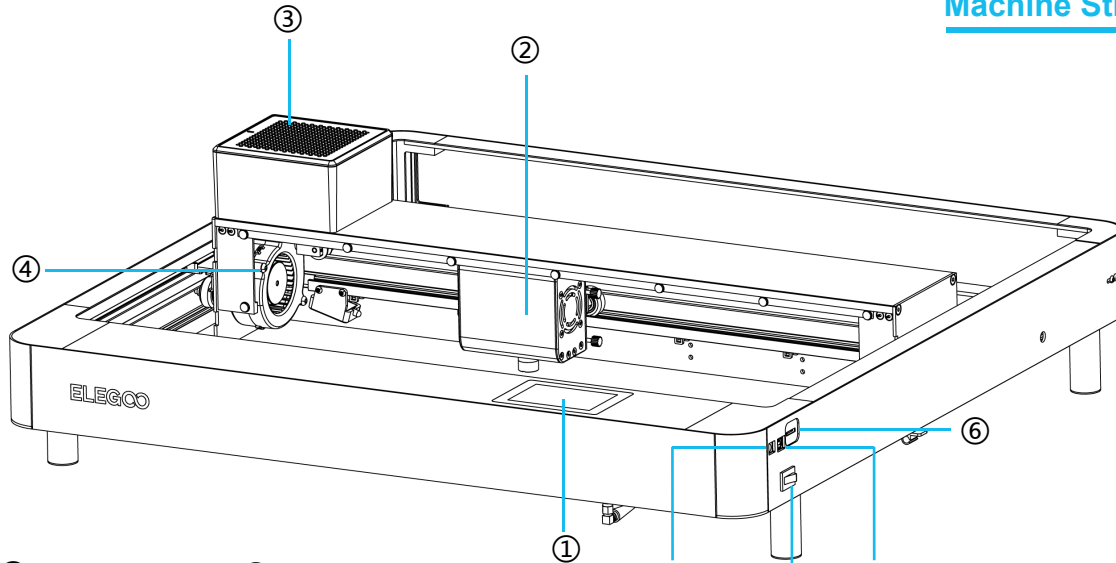

- | | |
|----------------|--------------------|
| ① Screen | ⑤ DC Socket |
| ② Laser Device | ⑥ TF Card Slot |
| ③ Air Filter | ⑦ Type-B Interface |
| ④ Turbo Fan | ⑧ Power Switch |

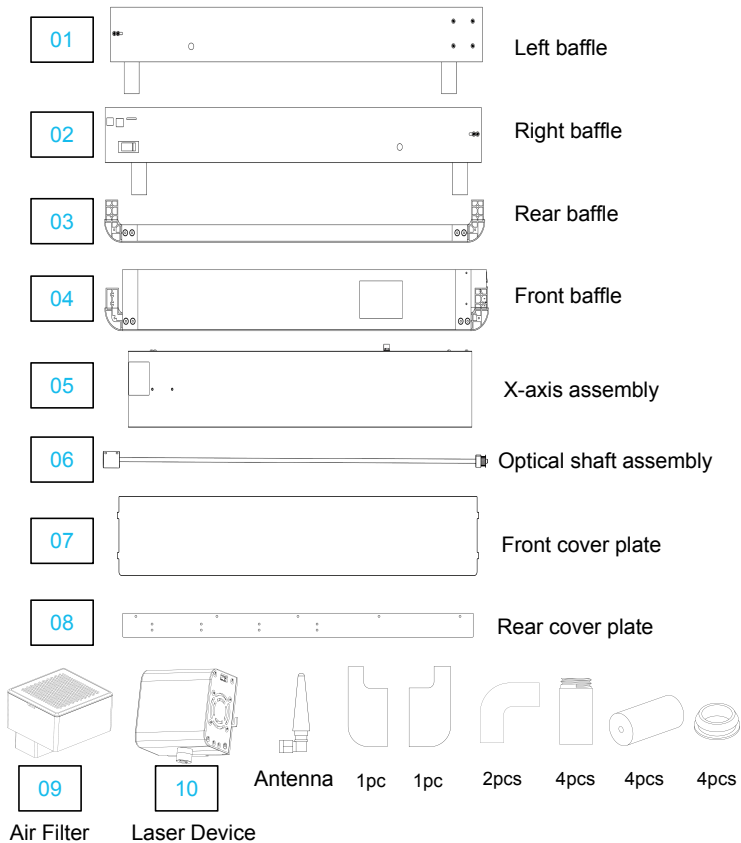

Packing List

(CM4*6) 16pcs

(KM4*8) 8pcs

(PM3*6) 7pcs

(PM4*16) 4pcs



Safety Goggles



Adapter



Wrench Tools

Card Reader



TF Card

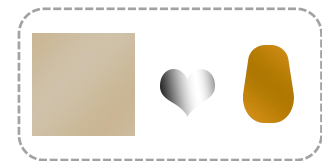

Engraving Material



USB Cable

The above accessories shall be subject to actual products, and the pictures are for reference only.

Machine Installation

①

The TF card of the machine comes with an installation instruction video.

- Pre-joined the four parts together on a horizontal plane.
- Please pay attention to the installation direction of the baffle.

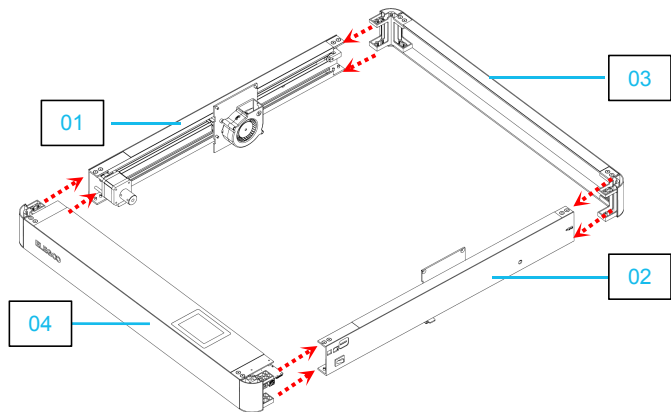

②

- Mount screws at the joint.
- Align the screws with the holes first, then tighten the screws.

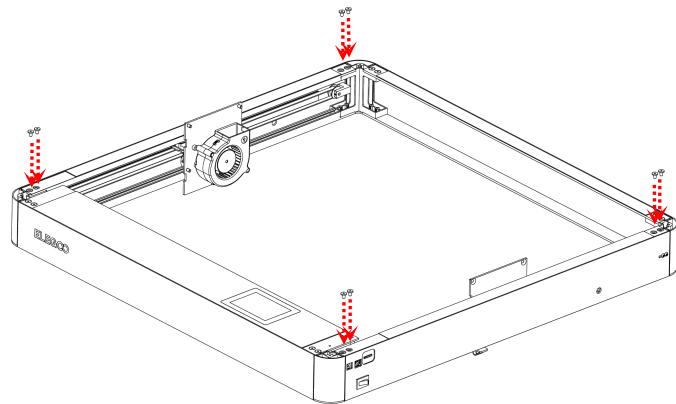

 (CM4*6) 8pcs

③

➤ Install and fix the bottom hole of the connection.

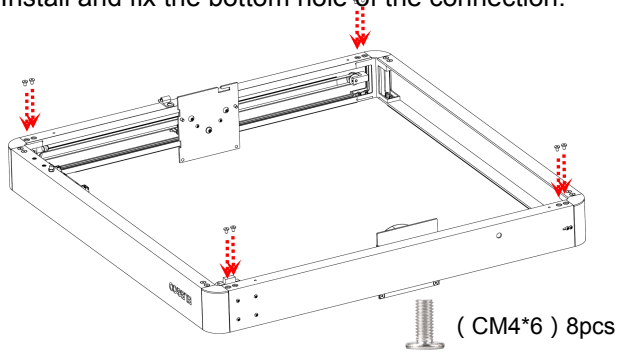

➤ Machine fixed foot installation

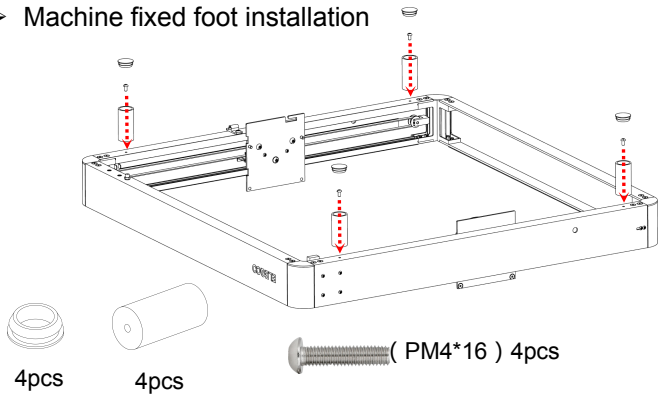

④

➤ Install and fix the X-axis assembly.

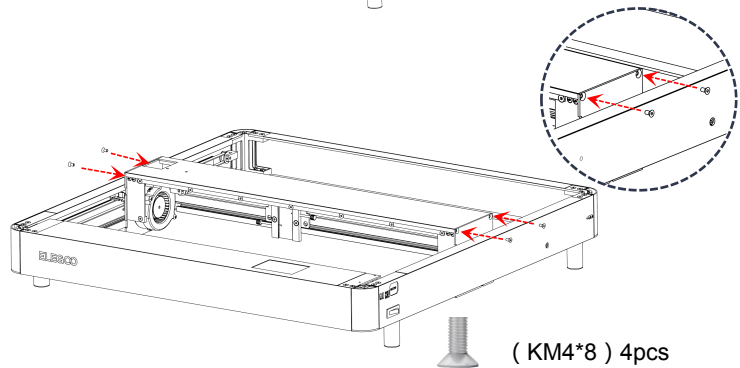
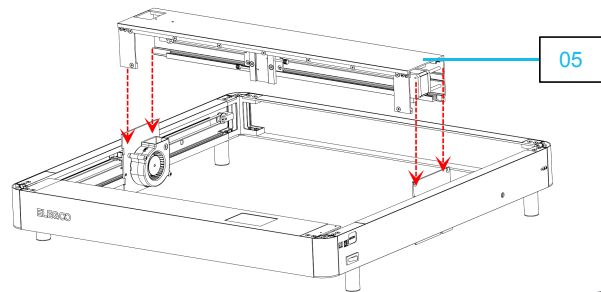

- Through the baffle holes reserved on both sides of the machine, move the middle parts to the corresponding holes and install and fix the screws respectively.

⑤

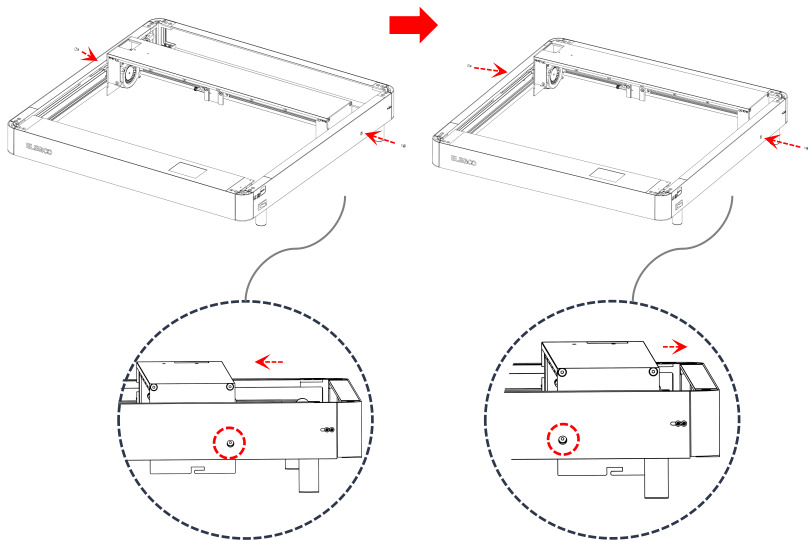

(KM4*8) 4pcs

- Install the axis assembly:

⑥

- ① When installing, drag the X-axis assembly against the front baffle. (keep the X-axis horizontal)
- ② Pass the synchronous wheel through the synchronous belt and fix it on the bearing.
- ③ Connect the coupling with the motor shaft and tighten the screws to fix it. (loosen the screws on the coupling during installation)

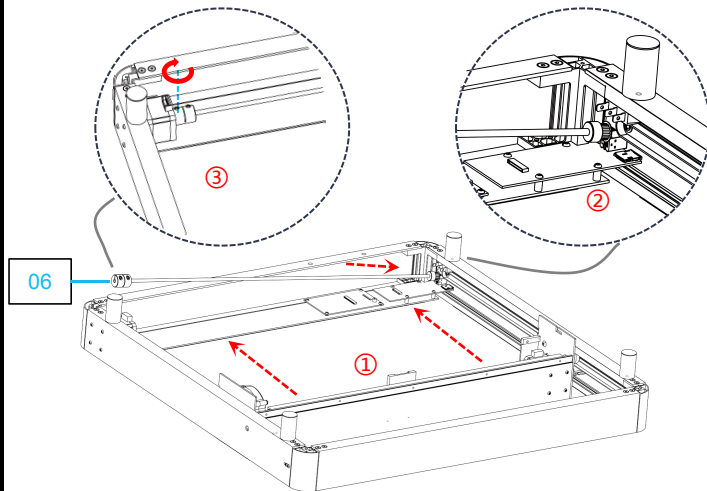

7

➤ **Timing Belt Installation:**

Install the timing belt with the tooth surface facing up into the slot.

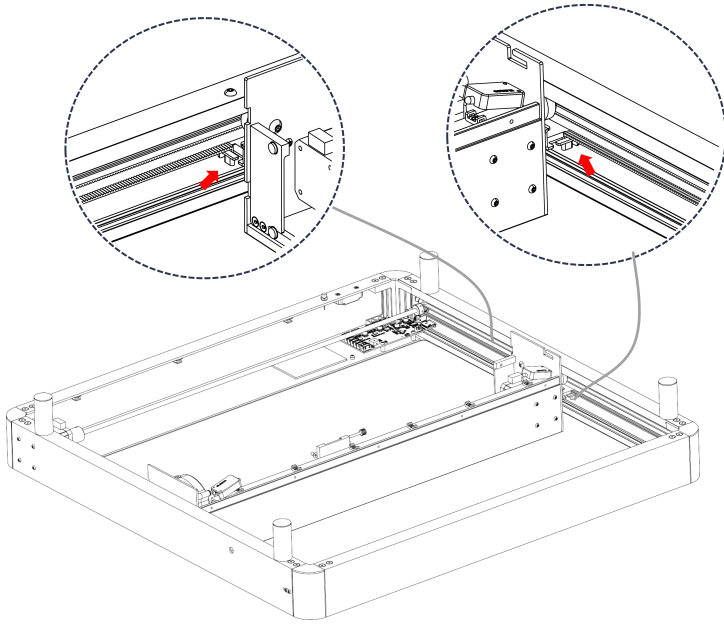

8

➤ **Timing Belt Adjustment:**

Loosen the side screws and tighten the adjustment slider of the timing belt towards one end. Then resecure the screws to lock it in place.

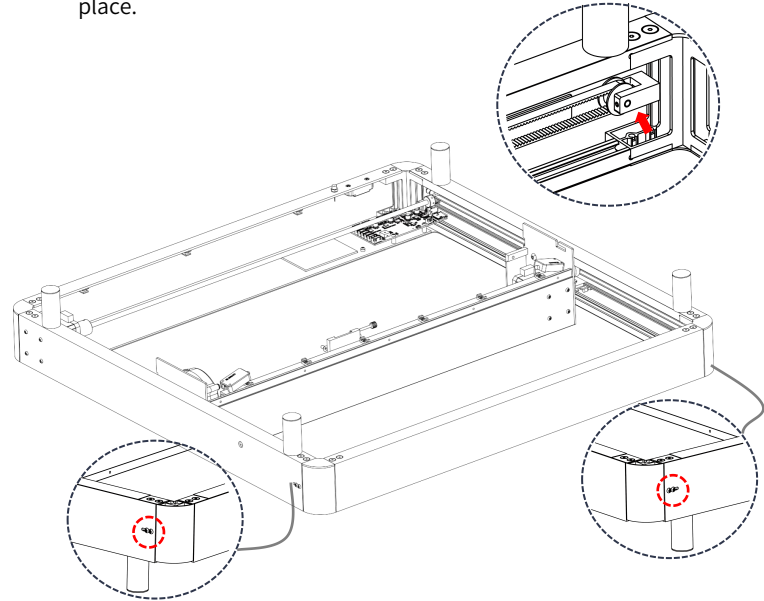

9

➤ Fixed rear cover plate

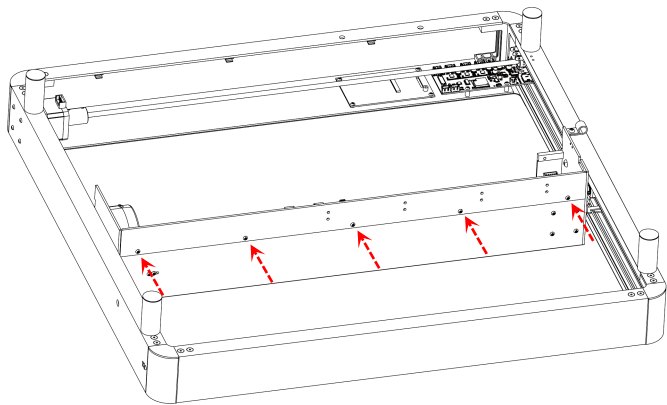

08



(PM3*6) 5pcs

10

➤ Connect the motherboard / Install antenna

➤ Connect to the corresponding location according to the identification code.

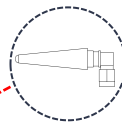
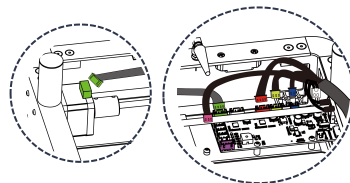
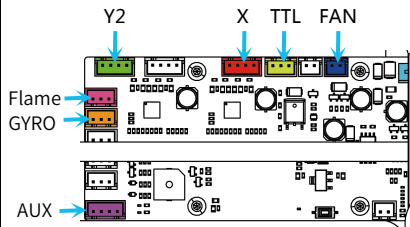

Antenna



10

➤ Installation of X-axis assembly wiring:

11

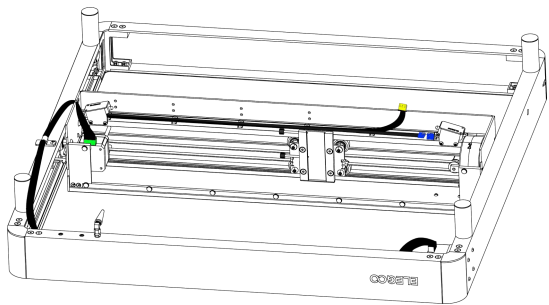

➤ Plug in the cable plug

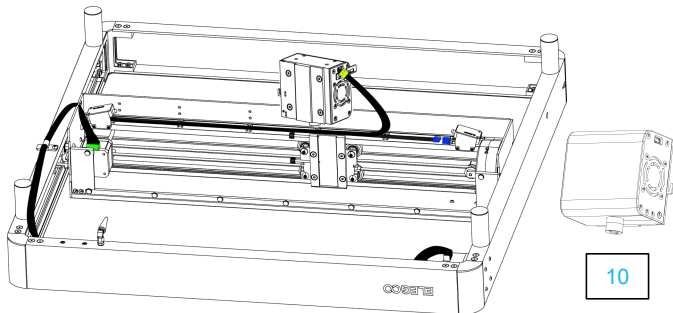

10

➤ Laser device installation:

Insert the laser device along the groove, and use the side screws to tighten it at the desired height.

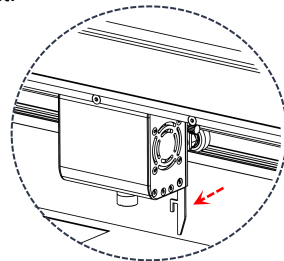
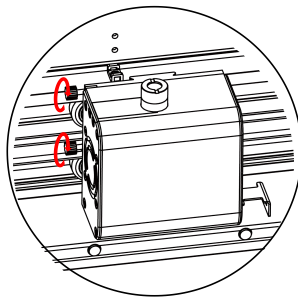

Pull out the focal length positioning bar, and tighten the screws on the side by the height where the protruding positioning bar contacts the engraving material.

➤ Air filter installation

13

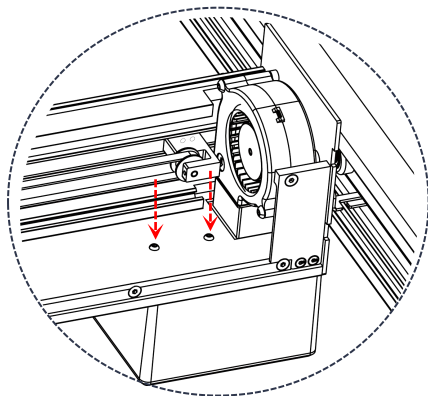

(PM3*6) 2pcs

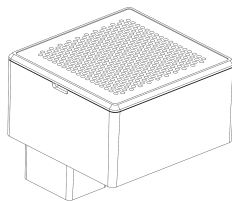

09

➤ Installation of front cover plate and rounded corner baffle

14

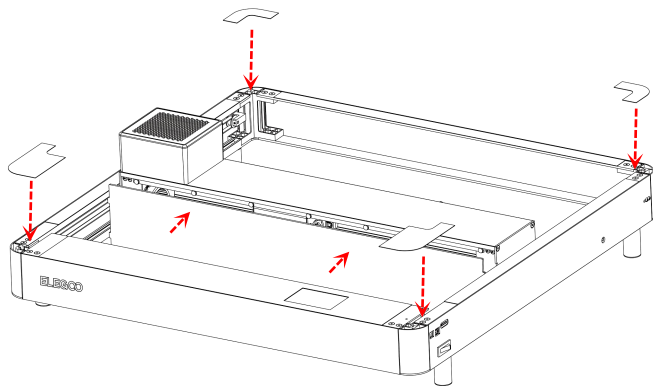

07

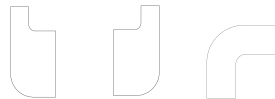

1pcs

1pcs

2pcs

Operation Screen Introduction

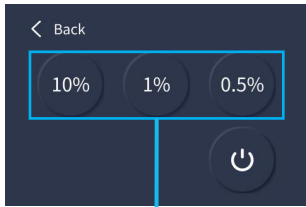
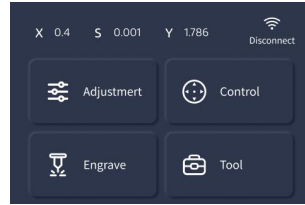

Laser power adjustment ratio
(This power value is used in positioning)



Unlock motor status

Move the laser head to the specified
position to locate the origin

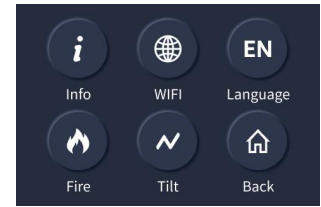
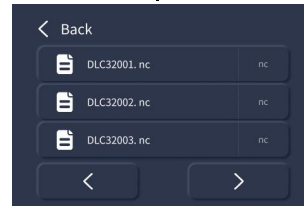

Select the file to be engraved,
determine the file position by stroke,
and then set the origin to engrave.

How to Use the Machine

This machine is compatible with a variety of slicing software on the market such as: LaserGRBL, LightBurn, and PHECDA APP. This operating instruction is based on the open-source software LaserGRBL.

1. TF card engraving: Save the file to the TF card by slicing through the LaserGRBL software, and select the required file through the control screen for engraving.
2. USB connection engraving: Connect computer and laser engraver through USB data cable, and control slice engraving through LaserGRBL software.
3. APP engraving: Install the PHECDA APP on your mobile phone, connect your mobile phone to the wifi of the machine, enter the machine's IP in the app, and you can operate the machine after a successful connection.

①

TF card engraving

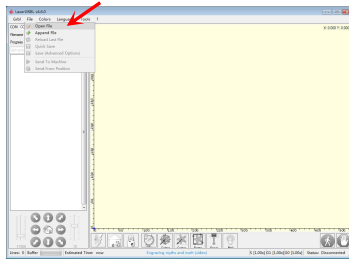

Import target image

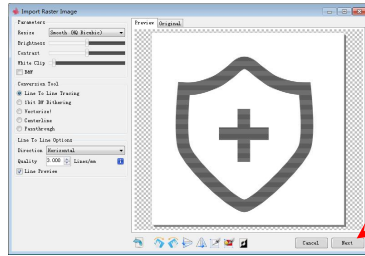

Select engraving type

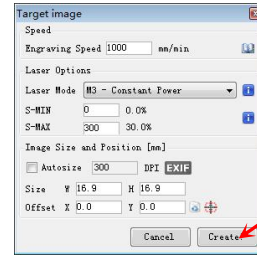

Adjust the image size and laser parameters

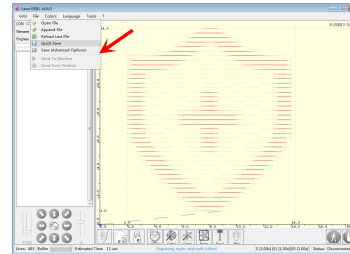
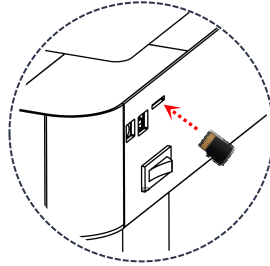

Place engraving material

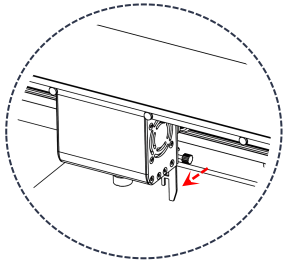
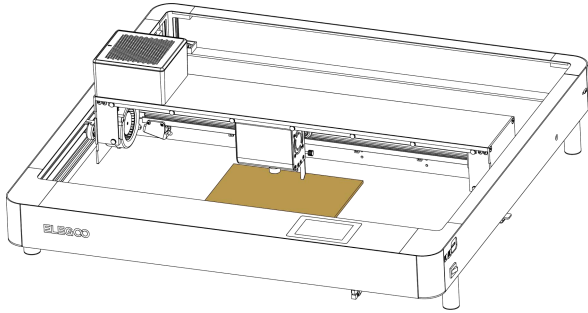

Pull out the focal length positioning bar, and tighten the screws on the side by the height where the protruding positioning bar contacts the engraving material.

Click to engrave

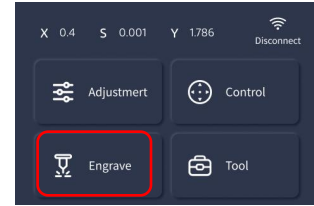

Select engraving file

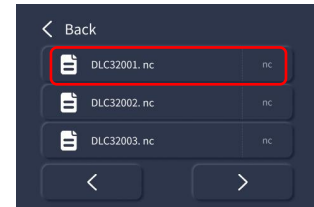

Select the plane mode →
select the positioning origin
→ make a stroke → confirm
the stroke position and then
engrave

①



③

②

Turn on the laser engraver, connect it to the computer via USB, double-click to open the engraving software, click the connect button, and the displayed data proves that the connection has been successful.
 (Note: you cannot open more than one slicing software at the same time, as there may be conflicts, and the port cannot be connected if it is occupied.)

②
 USB
 connection
 engraving

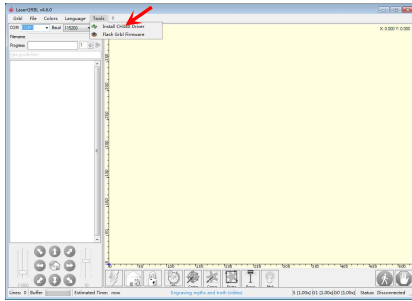

If the USB connection does not respond, install the CH340 driver through Tool

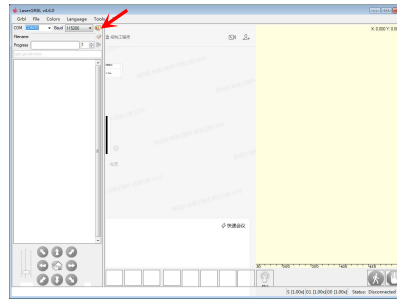

Click connect

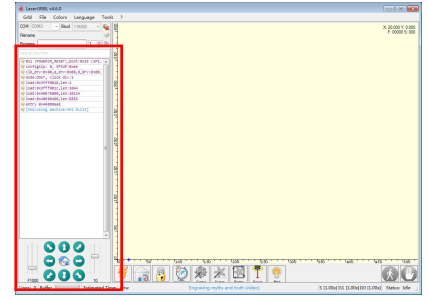

The connection is successful if the data displayed

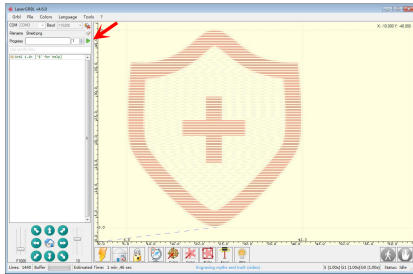

Just run the slicing program

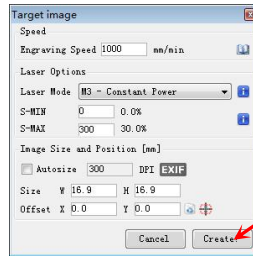

Adjust the image size and laser parameters

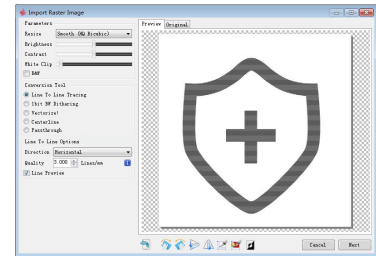

Import target image

Search "PHECDA APP" in your mobile app store to download

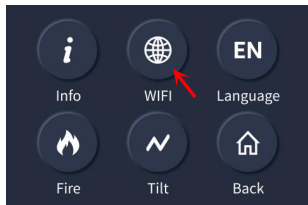

Click on the machine WiFi connection

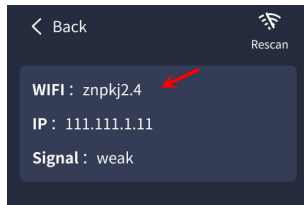

Select Connect

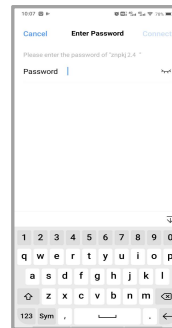

Connect to the WiFi signal on your device.
Default password: 12345678

③

APP engraving

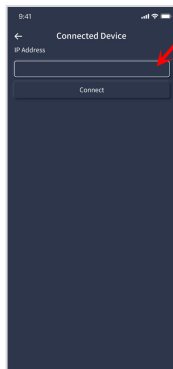

Enter the machine IP address to
connect successfully

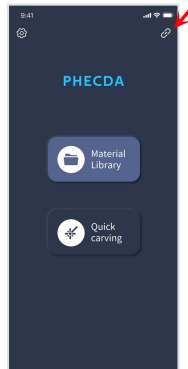

Open the PHECDA APP on your
mobile phone and click the button
indicated by the arrow



Note: When using the APP to  engrave and cut, you need to insert the TF card, otherwise you cannot upload the engraving files.

Motherboard Wiring

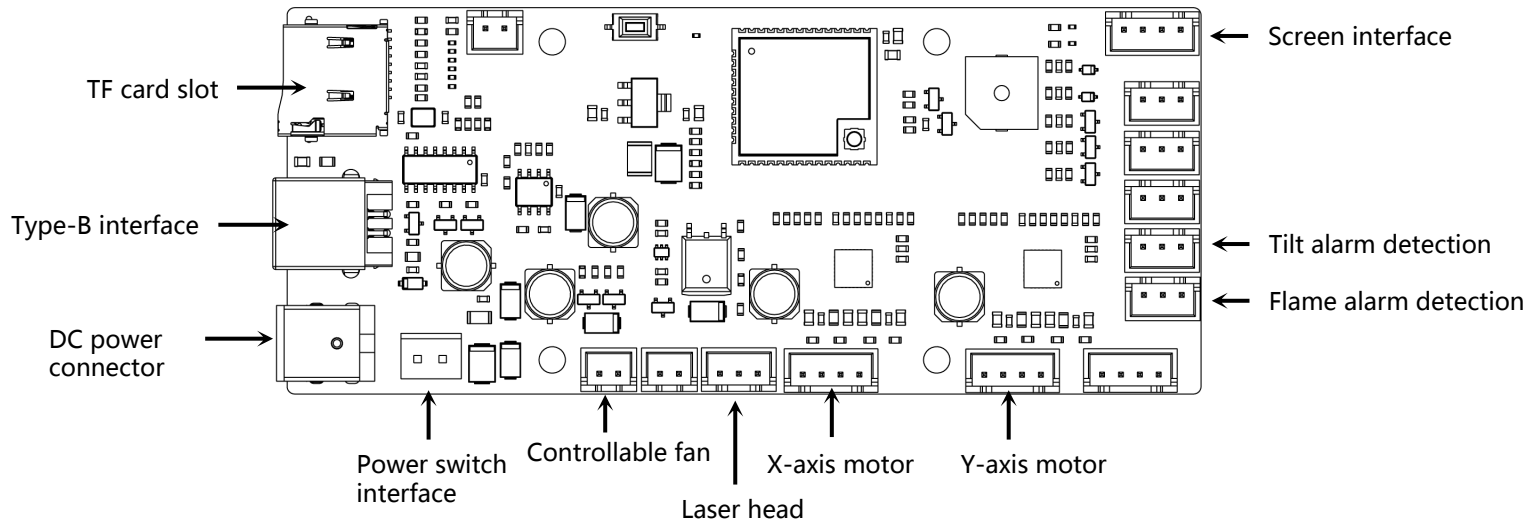

Maintenance Tips

- The window mirror of the laser head needs to be cleaned regularly after long-term use, because after a long period of cutting and engraving, the window mirror can cause poor light output due to smoke corrosion. (Wipe the window mirror with ethanol($\geq 75\%$))
- How to remove the window mirror:
The window mirror can be screwed out by putting the wrench handle into the groove.

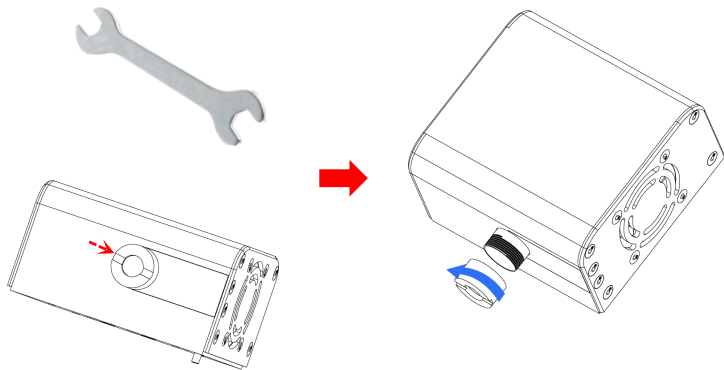

Air assist installation (optional)

Parts list

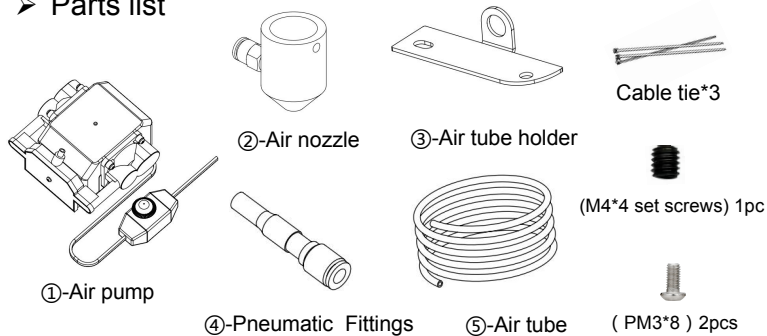

Accessories installation

- Remove the two screws on the lower left side of the laser device.

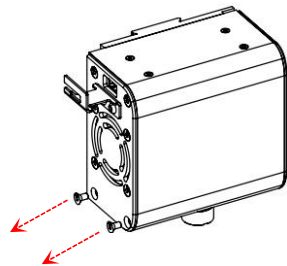

- Install the air tube holder

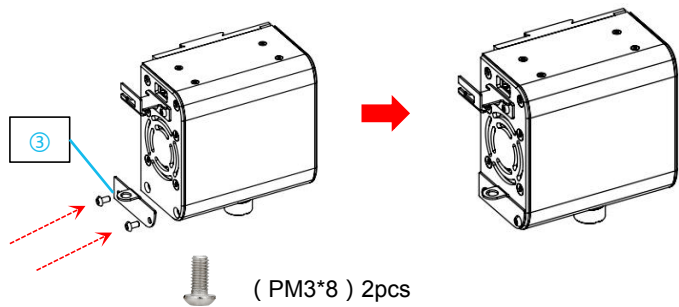

- Install the air nozzle

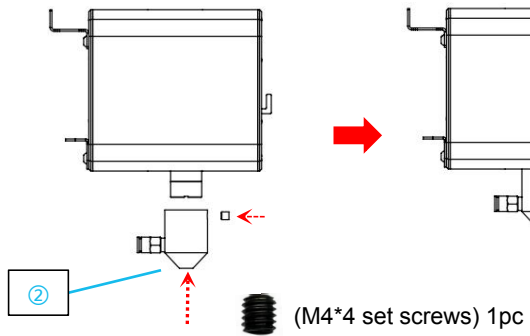

- Insert the air tube at the air tube end

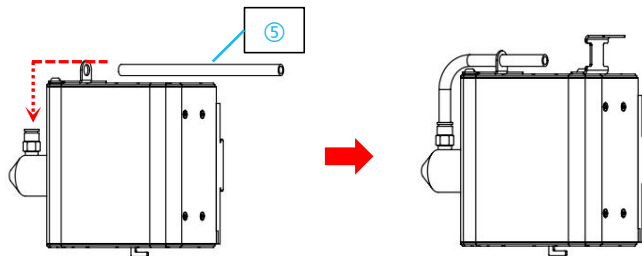

- Insert the air tube at the air pump end

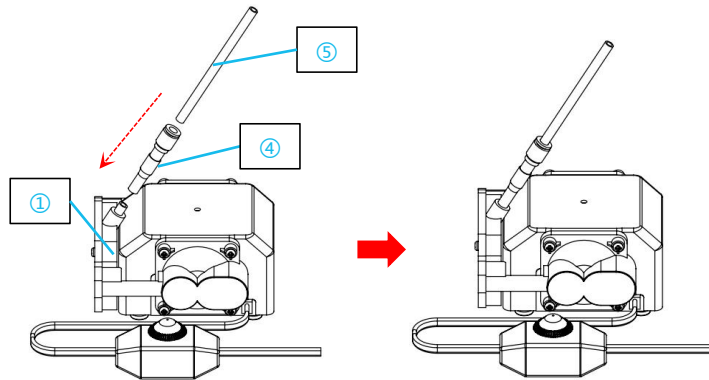

Finally, use a cable tie to fix the air tube and the laser device wire together to prevent the air tube from being scratched during movement.

PHECDA Grabadora Láser Manual de instrucciones

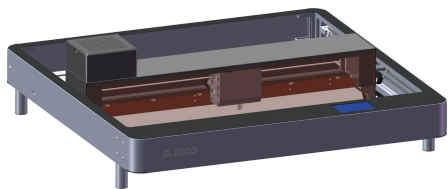

¡Gracias por elegir los productos ELEGOO!

Por su seguridad antes de utilizar el producto lea atentamente el manual de instrucciones. Las advertencias y consejos de este manual pueden ayudarle a evitar una instalación y un uso incorrectos.

Para preguntas o problemas que no se traten en este manual, póngase en contacto con nosotros a través de este correo electrónico:

3dp@elegoo.com

El equipo de ELEGOO estará siempre a su disposición para proporcionarle un servicio de calidad.

Para ofrecerle una mejor experiencia utilizando nuestros productos, puede obtener más información sobre este equipo a través de los siguientes medios:

- 1.El manual de instrucciones: puede encontrar el manual de instrucciones y videos sobre cómo utilizar la máquina en la tarjeta TF.
- 2.Página web oficial de ELEGOO: www.elegoo.com. Puede visitar nuestra web oficial para encontrar el manual de instrucciones necesario para esta máquina y también nuestra información de contacto.

Consejos de Seguridad

1. Mientras esté utilizando la grabadora láser, póngase gafas de protección láser para proteger sus ojos.
2. Mantenga el área de trabajo del equipo plana y limpia. Los residuos acumulados por el corte y grabado deben limpiarse regularmente para evitar riesgos de incendio.
3. No grabe ni corte materiales desconocidos, ya que la evaporación o fundición de muchos materiales desprenderá humos nocivos y puede causar lesiones físicas.
4. No utilice la máquina sin vigilarla. Si la máquina se configura incorrectamente antes de empezar a funcionar y no se supervisa durante mucho tiempo o tiene un fallo mecánico o eléctrico durante el funcionamiento, podría provocar un incendio.
5. Por favor, utilice la máquina en un área bien ventilada para que pueda expulsar los humos adecuadamente.
6. La máquina contiene piezas móviles de alta velocidad, así que tenga cuidado de no dañarse las manos.
7. Realice el mantenimiento del producto con frecuencia y limpie periódicamente el cuerpo de la máquina con un paño seco para eliminar el polvo y los residuos mientras la máquina está apagada.
8. Los niños deberán estar supervisados por adultos cuando utilicen la máquina para evitar posibles lesiones físicas.
9. En caso de emergencia, apague la máquina directamente.

Configuración de la grabadora

Modelo de máquina: PHECDA			
PHECDA (10W)		PHECDA (20W)	
Potencia del cabezal láser	10W	Potencia del cabezal láser	20W
Profundidad máxima de corte	≤8mm (tablero de tilo contrachapado)	Profundidad máxima de corte	≤14mm (tablero de tilo contrachapado)
Potencia	55W	Potencia	85W
Tensión	100V-240V 50/60Hz	Tensión	100V-240V 50/60Hz
Tensión de salida	24V	Tensión de salida	24V
Tamaño del láser	0.06mm×0.06mm	Tamaño del láser	0.07mm×0.13mm
Peso Neto	6.5kg	Peso Neto	6.7kg
Tipo de impresión	Grabado y corte láser	Ajuste de la altura del cabezal láser	0-75mm
Área de grabado	400mm×400mm	Tamaño de la máquina	673mm×660mm×190mm
Velocidad máxima de grabado	Eje X : 25000mm/min Eje Y : 18000mm/min	Compatible con APP	Sí
Longitud de onda del láser	455±5nm	Accesorios	accesorio giratorio, air assist
Funciones adicionales	Filtración de humos, detector de llamas, alerta de detección de inclinación	Idiomas	Chino, inglés, alemán, portugués, español ,francés, italiano
Sistema de explotación	windows/mac/ios/android	Formato de archivo compatible	SVG/DXF/JPG/JPEG/PNG/BMP/TIF, etc
Material del producto	Aleación de aluminio	Forma de conexión	Tarjeta TF, cable USB, APP

Ajustes del material

- Cuanto más lenta sea la velocidad, mayor será la potencia y profundidad de grabado. Por el contrario, cuanto más rápida sea la velocidad, menor será la potencia y profundidad de grabado.







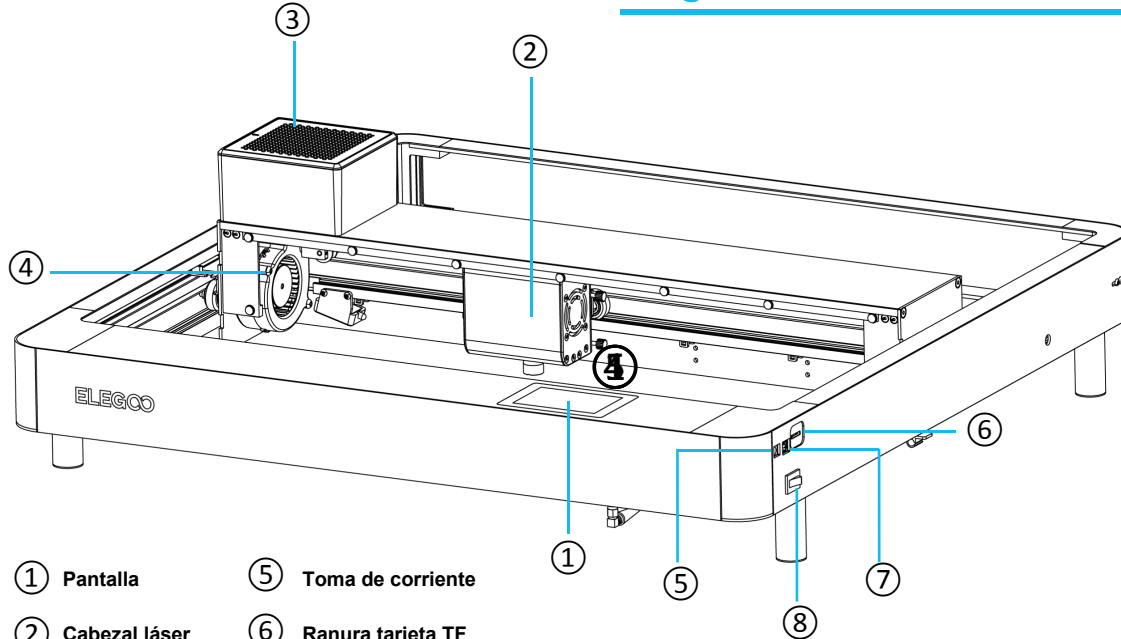



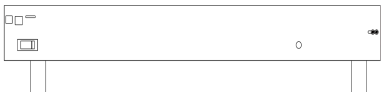





Material de Grabado	Función	10W			20W		
		Velocidad	Nº de pasadas	Potencia	Velocidad	Nº de pasadas	Potencia
Tablero de tilo contrachapado (3mm)	corte	180mm/min	1	55%	300mm/min	1	55%
	grabado	12000mm/min	1	95%	12000mm/min	1	65%
MDF (3mm)	corte	180mm/min	3	60%	300mm/min	1	100%
	grabado	12000mm/min	1	80%	12000mm/min	1	55%
Tablero de bambú(5mm)	corte	300mm/min	5	100%	180mm/min	1	90%
	grabado	6000mm/min	1	65%	12000mm/min	1	70%
Papel Kraft (150g)	corte	1800mm/min	1	50%	1800mm/min	1	30%
	grabado	12000mm/min	1	40%	18000mm/min	1	40%
Acero inoxidable	corte	/	/	/	/	/	/
	grabado	2000mm/min	1	100%	2000mm/min	1	50%
Tarjeta de visita de metal	corte	/	/	/	/	/	/
	grabado	6000mm/min	1	40%	6000mm/min	1	25%

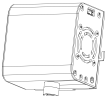



Los datos anteriores se han obtenido a partir de ensayos oficialmente realizados en laboratorio y el proceso de transformación real puede variar debido a las diferencias de materiales y entornos. Los ajustes basados en los ensayos son solo de referencia y pueden ajustarse en función de la situación real.

Diagrama de la estructura de la grabadora



- ① Pantalla
- ② Cabezal láser
- ③ Filtro de aire
- ④ Ventilador
- ⑤ Toma de corriente
- ⑥ Ranura tarjeta TF
- ⑦ Puerto USB
- ⑧ Interruptor on/off

- 01  Placa izquierda
- 02  Placa derecha
- 03  Placa trasera
- 04  Placa frontal
- 05  Montaje del eje X
- 06  Conjunto del eje del cabezal
- 07  Tapa frontal
- 08  Tapa trasera
- 09  Filtro de aire
- 10  Cabezal láser
-  Antena
-  1 pieza
-  1 pieza
-  2 piezas
-  4 piezas
-  4 piezas
-  4 piezas

-  (CM4*6) 16 piezas
-  (KM4*8) 8 piezas
-  (PM3*6) 7 piezas
-  (PM4*16) 4 piezas



Listado de Piezas

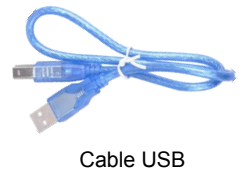
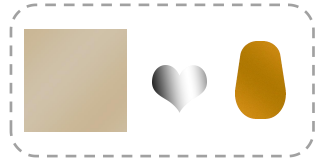

Los accesorios anteriores estarán sujetos a los productos reales y las imágenes son sólo de referencia.

Instalación de la grabadora

La tarjeta TF que se entrega con la máquina contiene un vídeo de instrucciones de instalación.

- Unir previamente las cuatro partes en una superficie plana.
- Tenga en cuenta la dirección de instalación de la tapa.

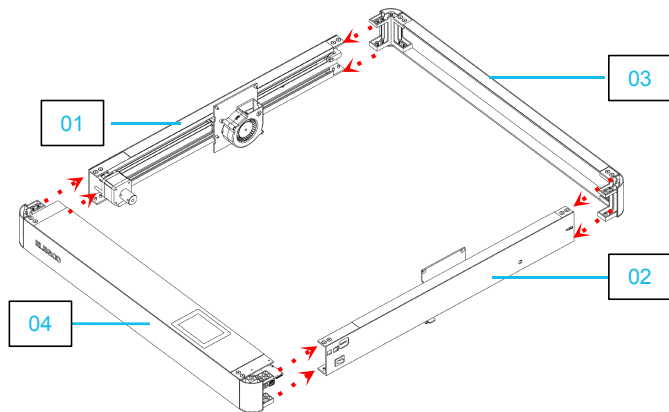

①

②

- Coloque los tornillos en las juntas.
- Alinee primero los tornillos con los orificios y a continuación apriételes.

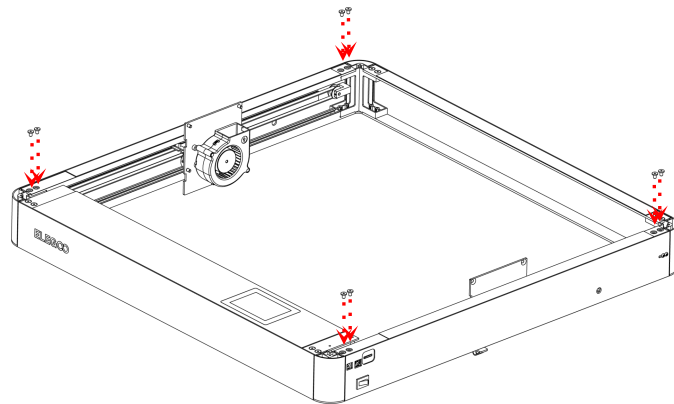

(CM4*6) 8 piezas

- Coloque los tornillos en la parte inferior de la máquina.

3

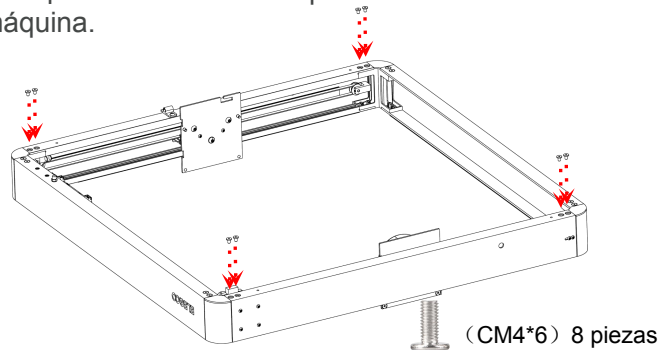

- Instale y fije las patas de la máquina

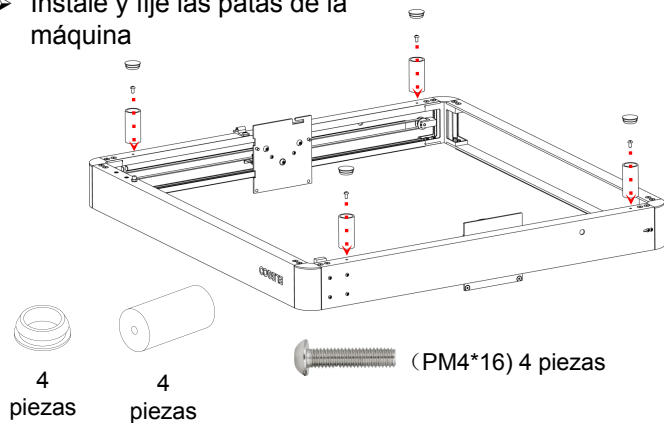

- Instale y fije el soporte del eje X.

4

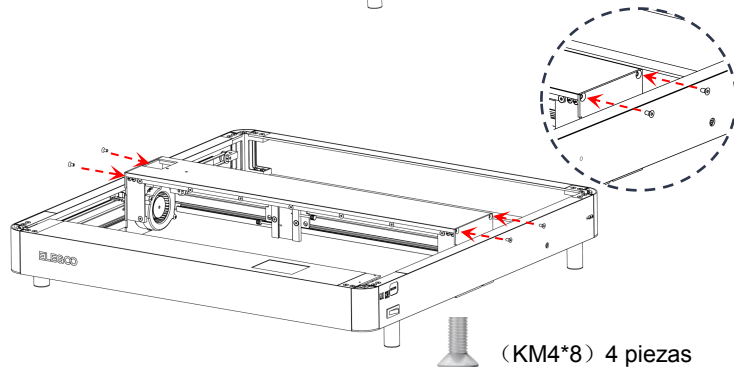
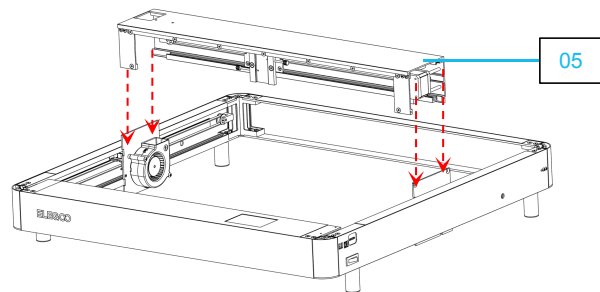

- Alinee las piezas del eje X con los agujeros restantes de los laterales de la tapa. Una vez alineados apriete los tornillos para fijarlo.

⑤

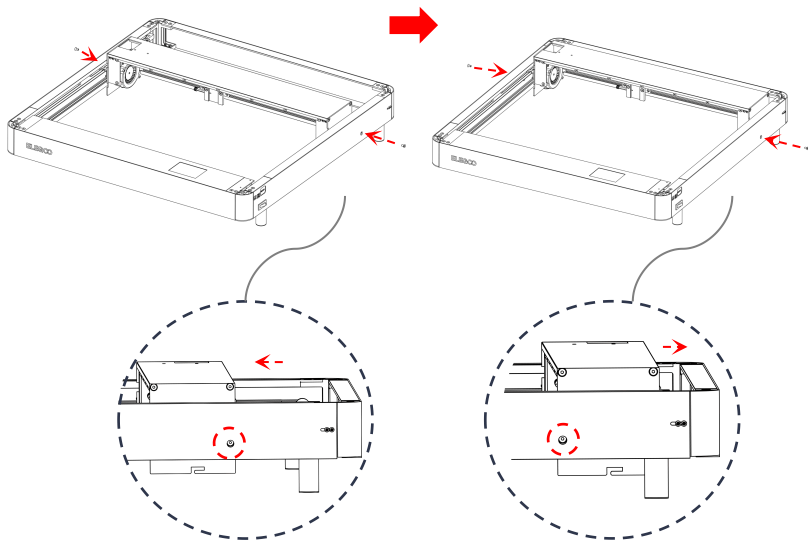

(KM4*8) 4 piezas

- Instalar el sistema de ejes :

⑥

- ① Al instalar, arrastre el conjunto del eje X contra la tapa delantera. (mantenga el eje X horizontal)
- ② Pase la rueda dentada por la correa dentada y fjela en el cojinete.
- ③ Conecte el enganche con el eje del motor y apriete los tornillos para fijarlo (afloje los tornillos del enganche durante la instalación).

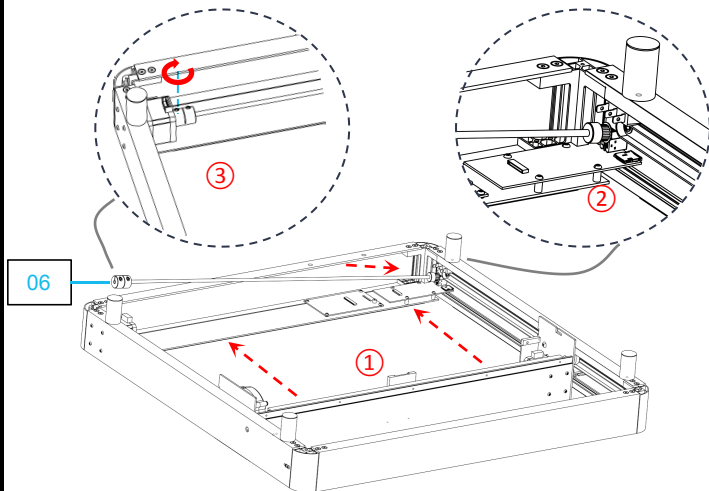

06

7

➤ **Instalación de la correa de distribución:**

Instale la correa de distribución con la superficie dentada hacia arriba en la ranura.

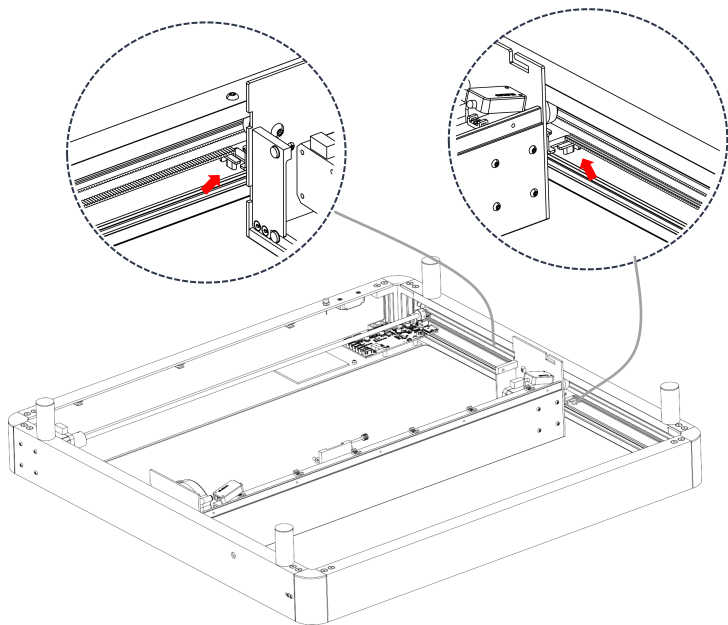

8

➤ **Ajuste la correa de distribución:**

Afloje los tornillos laterales y apriete el control deslizante de ajuste de la correa de distribución hacia un extremo. Vuelva a asegurar los tornillos para bloquearlo en su lugar.

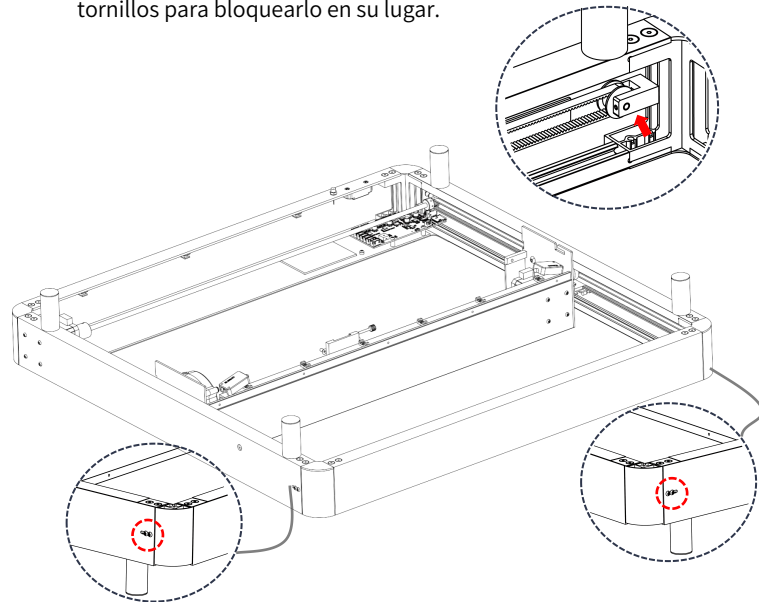

9

➤ Fijar la tapa trasera

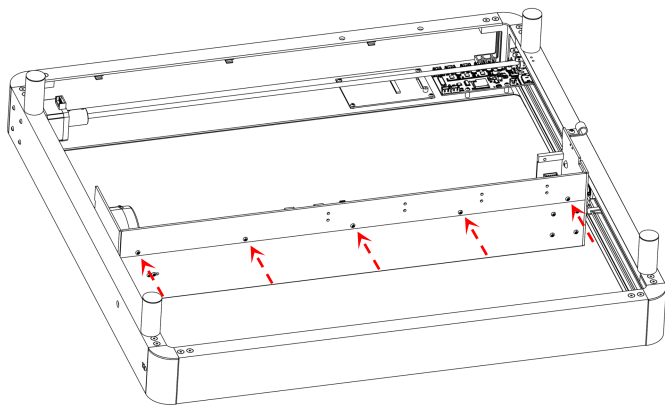

08



(PM3*6) 5 piezas

10

➤ Conectar la placa base / Instalar la antena

➤ Conecte los cables en el lugar correspondiente según el código de identificación..

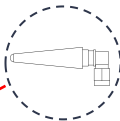
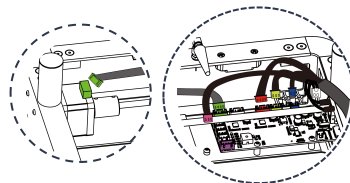
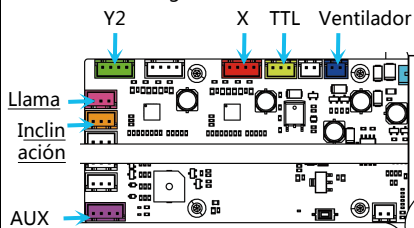

Antena

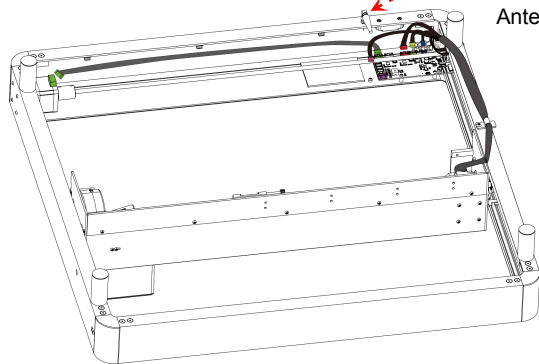

➤ Instalación del cableado del conjunto del eje X:

11

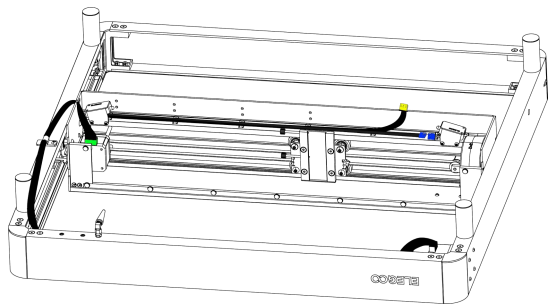

➤ Conecte el cable:

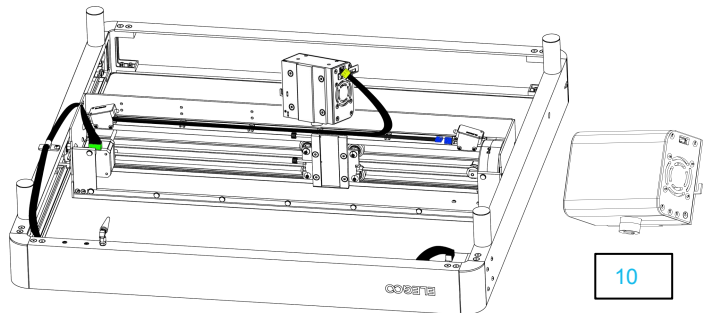

10

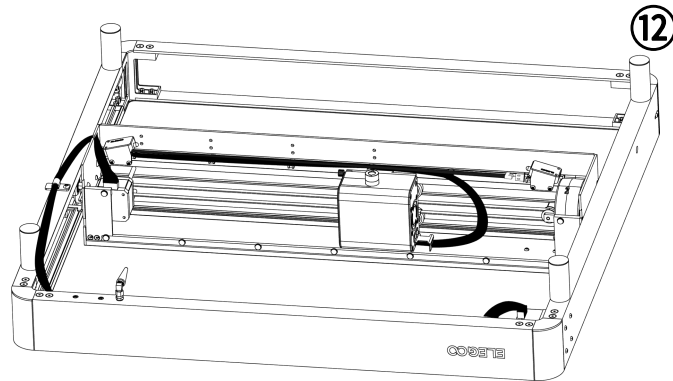

12

➤ Instalación del dispositivos láser:

Inserte el cabezal láser a lo largo de la ranura y utilice los tornillos laterales para apretarlo a la altura deseada.

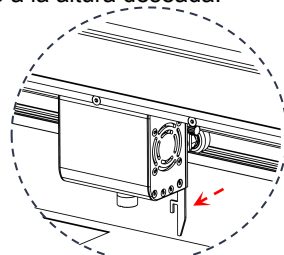
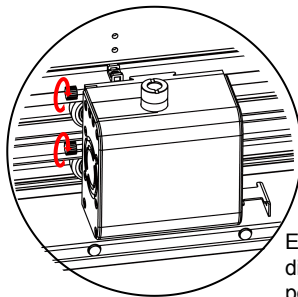

Extraiga la barra de posicionamiento de la distancia focal y apriete los tornillos del lateral por la altura en la que la barra de posicionamiento saliente entra en contacto con el material de grabado.

13

➤ Instalación del filtro de aire:

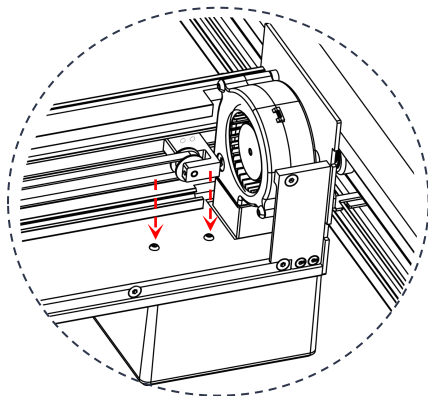

(PM3*6) 2 piezas

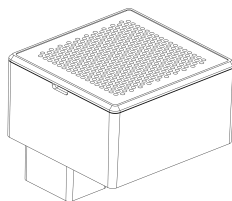

09

14

➤ Instalación de la cubierta frontal y de la tapa de esquinas redondeadas.

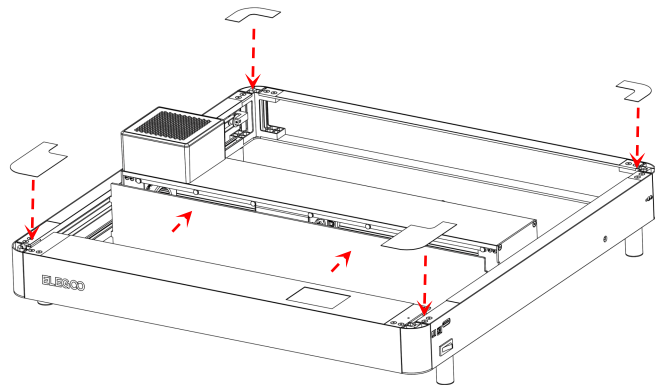

07



1
pieza



1
pieza



2
piezas

Pantalla de Control

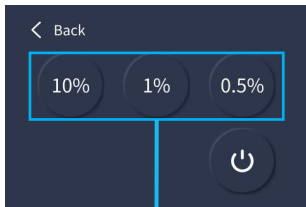
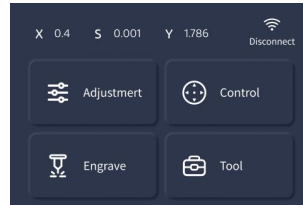

Ajuste de la potencia del láser
(Este valor de potencia se utiliza en
el posicionamiento)

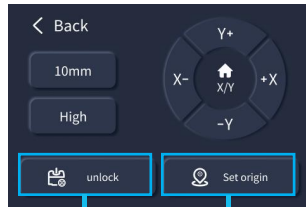

Estado de bloqueo
del motor

Mueva el cabezal láser a la posición
deseada para establecer el origen

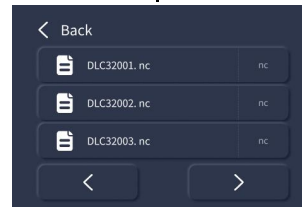

Seleccione el archivo que desea
grabar, determine la posición del
archivo marcando el perímetro y a
continuación, establezca la posición
de origen para grabar

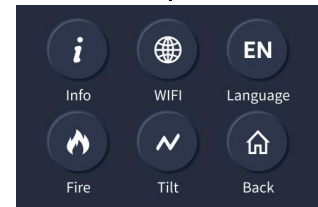

Cómo utilizar la grabadora

Esta máquina es compatible con varios softwares de corte que hay en el mercado tales como: LaserGRBL, LightBurn y PHECDA APP. Estas instrucciones de funcionamiento se basan en el software de código abierto LaserGRBL.

1. Grabado en Tarjeta TF: Guarde el archivo en la tarjeta TF y seleccione el archivo necesario a través de la pantalla de control para el grabado.
2. Grabado por conexión USB: Conecte el ordenador y el grabador láser a través del cable de datos USB y controle el grabado a través del software LaserGRBL.
3. Grabado con APP: Instale la APP PHECDA en su teléfono móvil, conecte su teléfono móvil al wifi de la grabadora, introduzca la IP de la grabadora en la app, y tras una correcta conexión podrá utilizar la grabadora.

1

Grabado en TarjetaTF

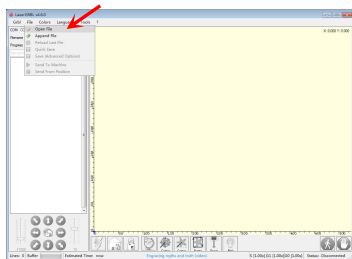

Importar imagen de destino

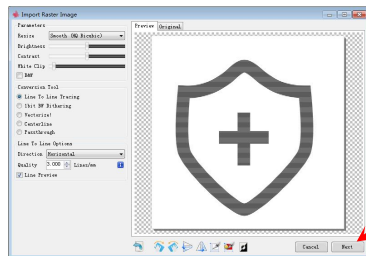

Seleccione el tipo de grabado

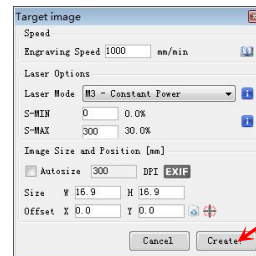

Ajuste el tamaño de la imagen y los parámetros del láser

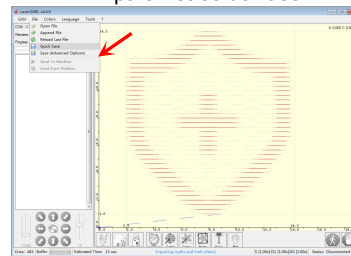
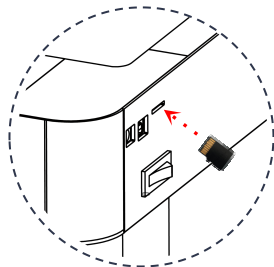

Guarde el archivo de corte en la tarjeta TF

Coloque el material a grabar

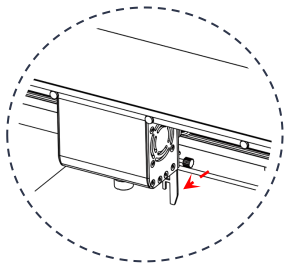
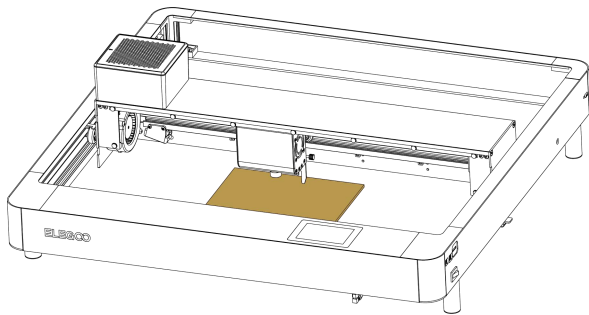

Extraiga la barra de posicionamiento de la distancia focal y apriete los tornillos del lateral por la altura en la que la barra de posicionamiento saliente entra en contacto con el material de grabado.

Haga clic para grabar

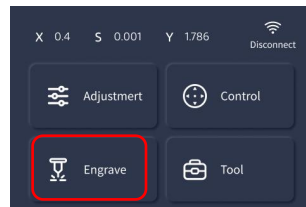

Seleccione el archivo de grabado

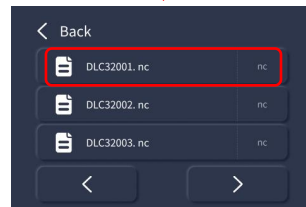

Seleccione el modo plano → ①
seleccione establecer el origen → marcar el perímetro → confirme y grave



Encienda la grabadora láser, conéctela al ordenador a través de USB, haga doble clic para abrir el software de grabado, haga clic en el botón de conexión y los datos que aparezcan confirmarán que la conexión se ha realizado correctamente.

(Nota: no se puede abrir más de un software de grabado al mismo tiempo ya que puede haber conflictos. El puerto no se puede conectar si ya está ocupado).

2

Grabado con conexión USB

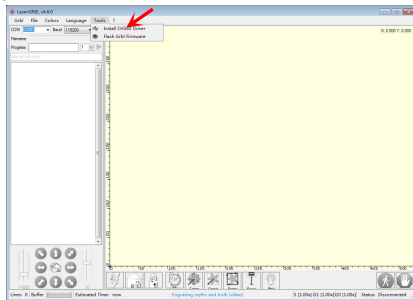

Si la conexión USB no responde, instale el controlador CH340 a través de Tool

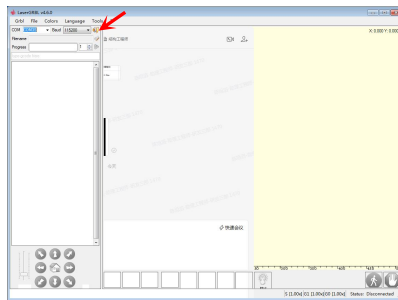

Haga clic en conectar

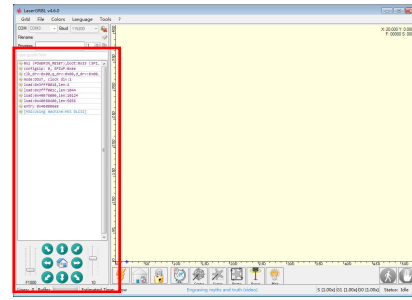

La conexión es correcta si aparecen los datos en la pantalla

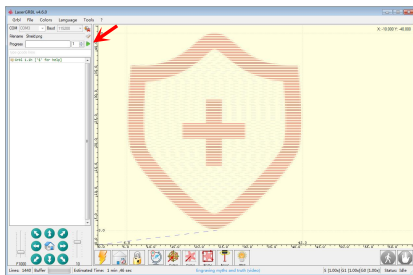

Simplemente ejecute el programa de corte

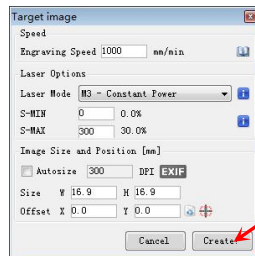

Ajuste el tamaño de la imagen y los parámetros del láser

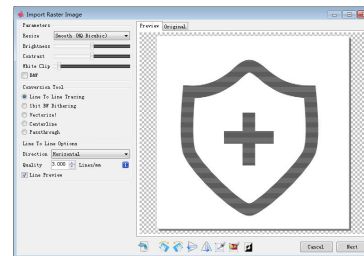

Importar imagen de destino

Busque "PHECDA APP" en la tienda de aplicaciones de su móvil para descargarla.

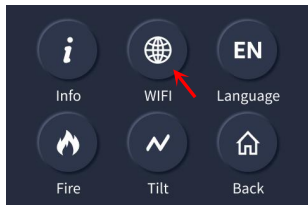

Haz clic en la conexión WiFi de la grabadora

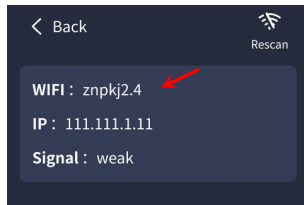

Seleccione Conectar

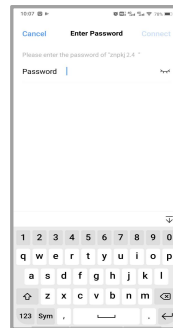

Conéctese a la señal WiFi de su dispositivo.
Contraseña predeterminada: 12345678

3

APP de Grabado

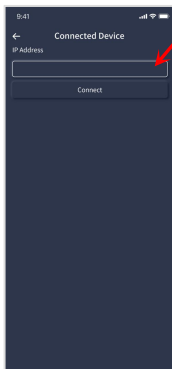

Introduzca la dirección IP de la grabadora para conectarse correctamente

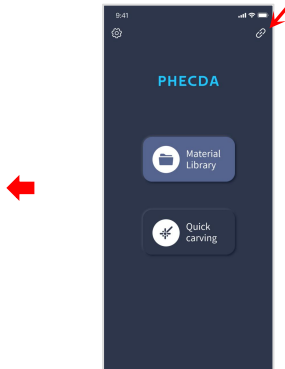

Abra la APP PHECDA en su teléfono móvil y haga clic en el botón indicado por la flecha



Nota: Cuando se utiliza la APP para grabar y cortar, es necesario insertar la tarjeta TF, de lo contrario no se podrán cargar los archivos de grabado.

Cableado de la placa base

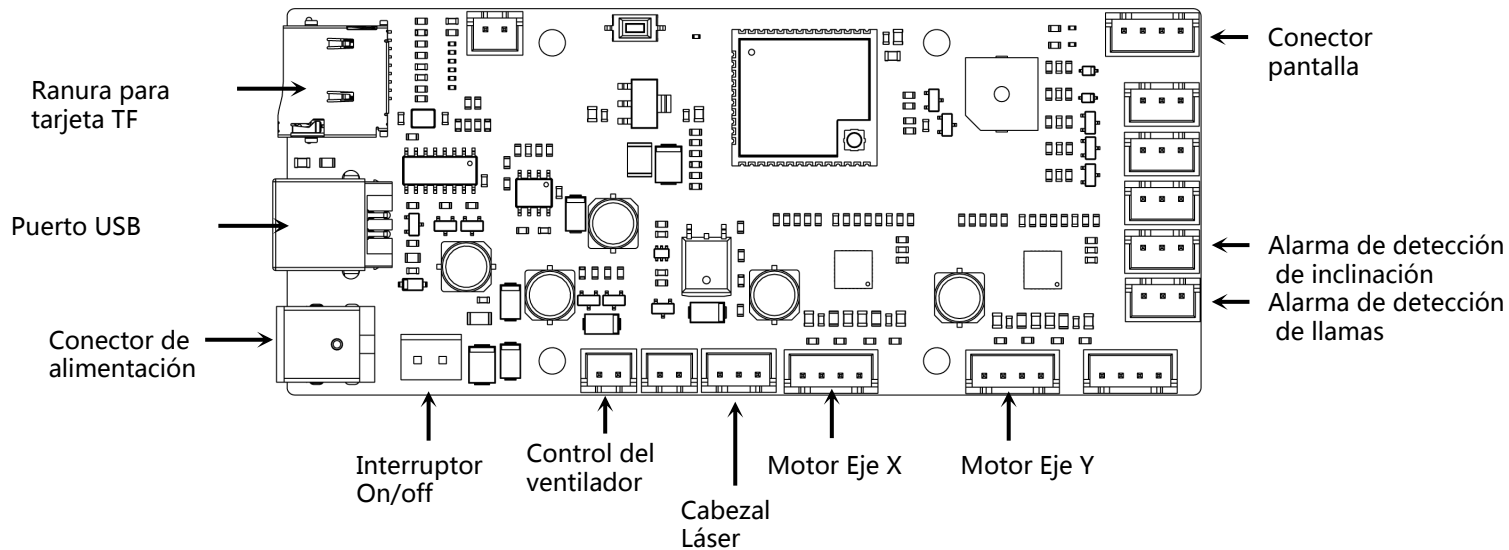

Mantenimiento

- La lente de vidrio del cabezal láser debe limpiarse regularmente después de un uso prolongado. Después de un largo período de corte y grabado, la lente puede causar una alteración de la potencia de luz debido a la corrosión por el humo. (Limpie la lente con etanol($\geq 75\%$)).
- Cómo quitar la lente de vidrio: la lente de vidrio puede desatornillarse introduciendo el mango de la llave en la ranura.

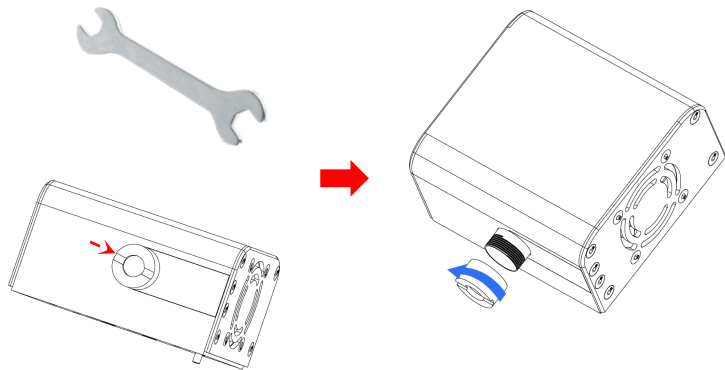

Instalación del Air Assist (opcional)

Listado de piezas:

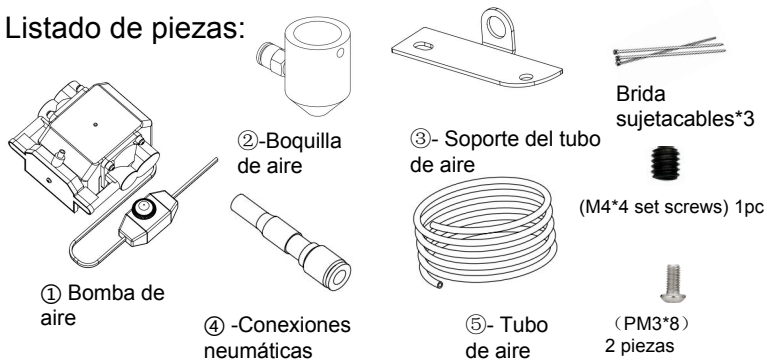

- Instalación de accesorios
- Retire los dos tornillos de la parte inferior izquierda del dispositivo láser.

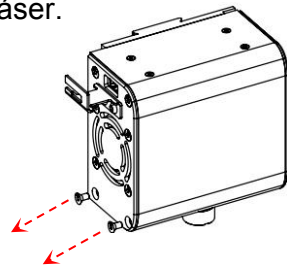

- Instale el soporte del tubo de aire

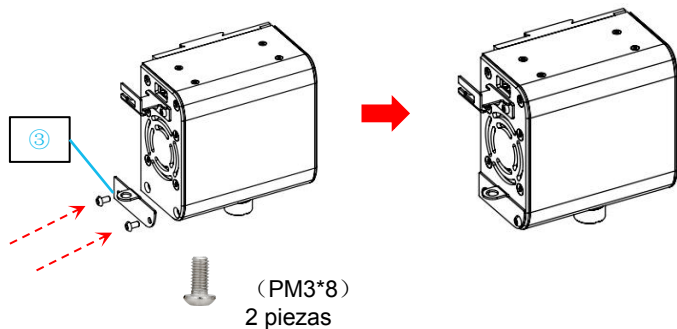

- Instale la boquilla de aire

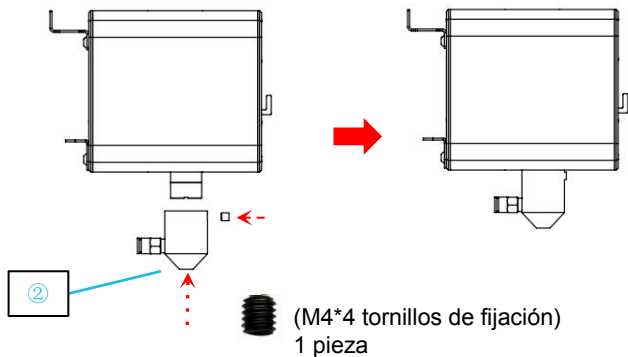

- Inserte el tubo de aire en el extremo del tubo de aire

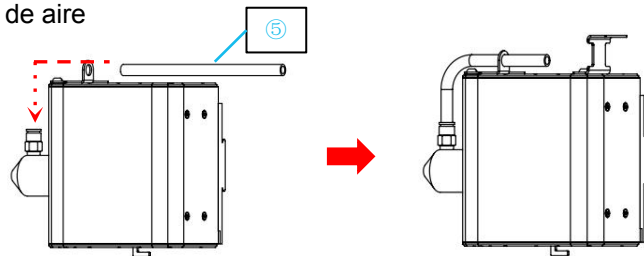

- Inserte el tubo de aire en el extremo de la bomba de aire

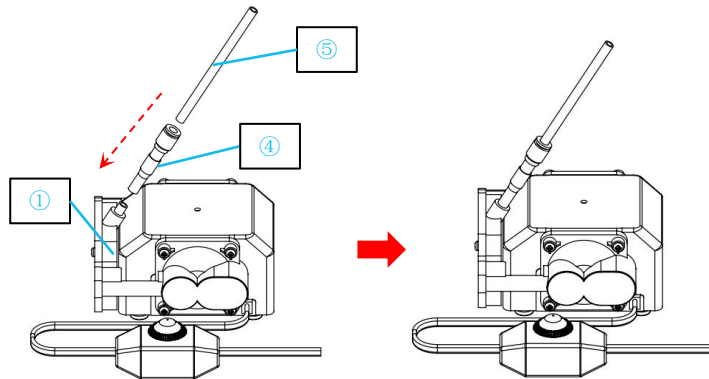

Por último, utilice una brida para cables para fijar el tubo de aire y el cable del dispositivo láser juntos para evitar que el tubo de aire se dañe durante su uso

PHECDA Laser Engraver Manuale

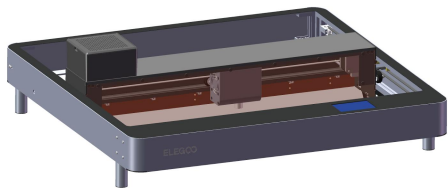

Grazie per aver scelto i prodotti ELEGOO!

Per un impiego corretto, leggere con attenzione questo manuale prima dell'utilizzo. Gli avvertimenti e i consigli presenti aiuteranno ad evitare un'installazione e/o un utilizzo scorretti.

Per domande o problemi non trattati in questo manuale, contattaci al seguente indirizzo mail: 3dp@elegoo.com

Il team ELEGOO è sempre pronto ad offrirti un servizio di qualità .

Per offrirti una migliore esperienza di utilizzo dei nostri prodotti, puoi imparare sempre di più riguardo a questo dispositivo nei seguenti modi:

1. Manuale di istruzioni: Troverai le istruzioni operative più importanti e dei video su come far funzionare la macchina con una scheda SD.
2. Sito Ufficiale ELEGOO: www.elegoo.com. Puoi visitare il nostro sito ufficiale per trovare le istruzioni principali su come utilizzare questo dispositivo e le informazioni per contattarci.

Sicurezza

1. Durante l'utilizzo dell'incisore laser, indossare gli occhiali di protezione laser per proteggere gli occhi.
2. Tenere l'area di lavoro della macchina in piano e pulita. Frammenti accumulati durante dal taglio e incisione devono essere puliti regolarmente per evitare il rischio di provocare incendi.
3. Non incidere o tagliare materiali sconosciuti, poiché la vaporizzazione o la fusione di certi materiali causerà il rilascio di fumi dannosi che provocheranno lesioni personali.
4. Non lasciare incustodita la macchina mentre è in funzione. Se la macchina non è stata impostata correttamente e viene lasciata incustodita a lungo, potrebbero presentarsi problemi meccanici e/o elettrici che causeranno un incendio.
5. Utilizzare la macchina in una zona ben ventilata in modo che i fumi possano essere estratti correttamente.
6. La macchina è dotata di componenti in movimento ad alta velocità, non metterci le mani durante il funzionamento.
7. Effettuare spesso la manutenzione del prodotto e pulire periodicamente il telaio della macchina con un panno asciutto per rimuovere polvere e frammenti quando la macchina è spenta.
8. I bambini devono essere supervisionati da un adulto quando la macchina è in funzione per evitare lesioni personali.
9. In caso di emergenza togliere immediatamente l'alimentazione.

Caratteristiche della Macchina

Modello della Macchina: PHECDA			
PHECDA (10W)		PHECDA (20W)	
Potenza del Laser	10W	Potenza del Laser	20W
Spessore massimo di Taglio	≤8mm (tavola di Taglio)	Spessore massimo di Taglio	≤14mm (tavola di Taglio)
Potenza della Macchina	55W	Potenza della Macchina	85W
Tensione Nominale	100V-240V 50/60Hz	Tensione Nominale	100V-240V 50/60Hz
Tensione in Uscita	24V	Tensione in Uscita	24V
Dimensione del Laser	0.06mm×0.06mm	Dimensione del Laser	0.07mm×0.13mm
Peso Netto	6.5kg	Peso Netto	6.7kg
Principio di funzionamento	Incisione e taglio laser	Regolazione dell'altezza della testa Laser	0-75mm
Area di incisione	400mm×400mm	Dimensioni della macchina	673mm×660mm×190mm
Velocità massima di incisione	X-axis : 25000mm/min Y-axis : 18000mm/min	Supporto APP	Si
Lunghezza d'onda del laser	455±5nm	Accessori	rotary attachment, air assist
Funzioni ausiliarie	Filtraggio dei fumi, sensore di fiamma, sensore di rilevazione di ribaltamento	Lingue supportate	Cinese, Inglese, Tedesco, Portoghese, Spagnolo, Francese, Italiano
Support system	windows/mac/ios/android	File supportati	SVG/DXF/JPG/JPEG/PNG/BMP/TIF, ecc
Materiale del prodotto	Lega di alluminio	Metodo di connessione	Scheda SD, cavo USB, APP

Parametri per i Materiali

- Più è bassa la velocità, più è alto il rapporto di potenza di incisione e maggiore sarà la profondità di incisione. Al contrario, più è alta la velocità, più è basso il rapporto di potenza di incisione e minore sarà la profondità di incisione.

Materiale da incidere	Operazione	10W			20W		
		Velocità	Passate	Potenza	Velocità	Passate	Potenza
Compensato (3mm)	Taglio	180mm/min	1	55%	300mm/min	1	55%
	Incisione	12000mm/min	1	95%	12000mm/min	1	65%
MDF (3mm)	Taglio	180mm/min	3	60%	300mm/min	1	100%
	Incisione	12000mm/min	1	80%	12000mm/min	1	55%
Tavola di Bambù (5mm)	Taglio	300mm/min	5	100%	180mm/min	1	90%
	Incisione	6000mm/min	1	65%	12000mm/min	1	70%
Cartoncino (150g)	Taglio	1800mm/min	1	50%	1800mm/min	1	30%
	Incisione	12000mm/min	1	40%	18000mm/min	1	40%
Acciaio Inox	Taglio	/	/	/	/	/	/
	Incisione	2000mm/min	1	100%	2000mm/min	1	50%
Biglietto da visita in metallo	Taglio	/	/	/	/	/	/
	Incisione	6000mm/min	1	40%	6000mm/min	1	25%

I dati precedenti sono ricavati da test in laboratori ufficiali, ma i parametri di processo effettivi potrebbero variare a causa di differenze nei materiali e dell'ambiente. Le impostazioni basate sui test sono da utilizzare come riferimento e possono essere modificati in accordo ai risultati ottenuti.

Diagramma della Macchina

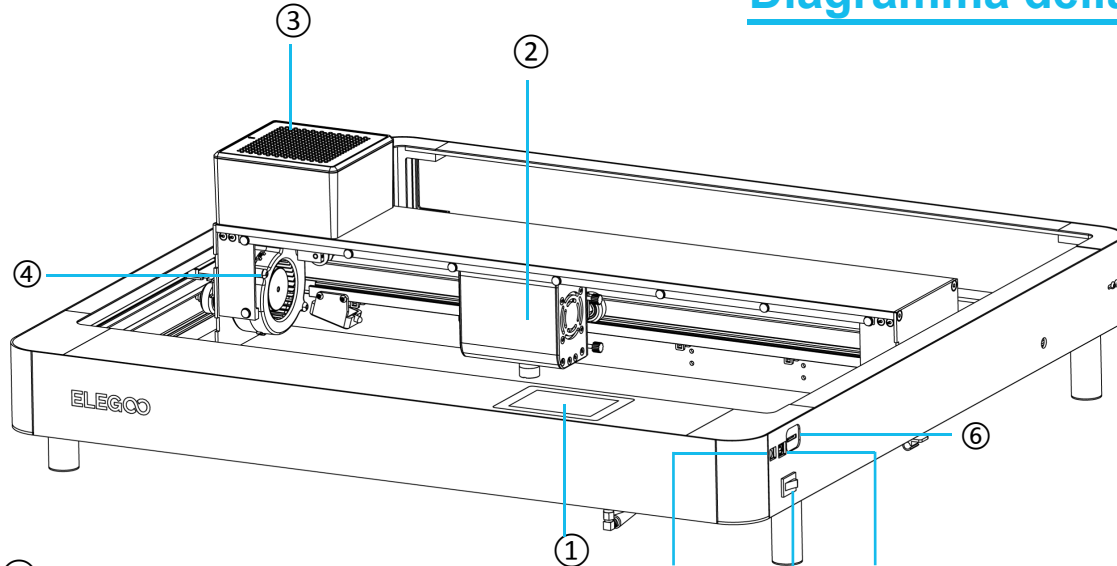

- | | |
|--------------------|-------------------------|
| ① Schermo | ⑤ Presa di Corrente DC |
| ② Testa Laser | ⑥ Slot per la Scheda SD |
| ③ Filtro dell'Aria | ⑦ Interfaccia USB |
| ④ Ventola | ⑧ Interruttore |

Contenuto

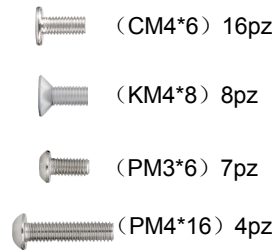
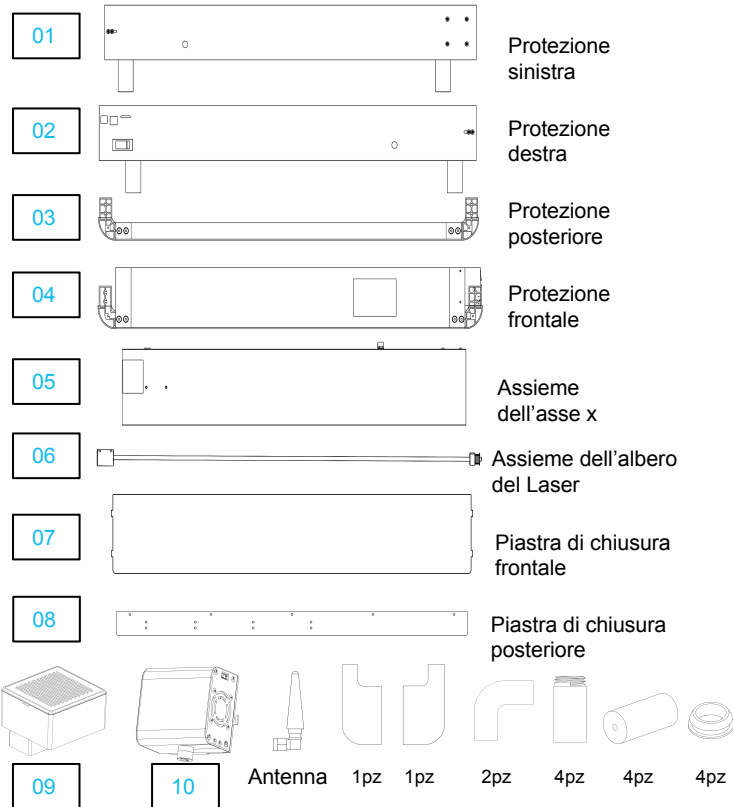

Occhiali Protettivi



Adattatore



Materiali da Incidere



Cavo USB

Gli accessori precedenti potrebbero differire dai prodotti effettivi e le immagini sono a solo scopo illustrativo.

Installazione della Macchina

La scheda SD, fornita con la macchina, contiene un video con le istruzioni per l'assemblaggio.

- Pre-assemblare le quattro parti su un piano orizzontale.
- Fare attenzione al verso di installazione delle protezioni.

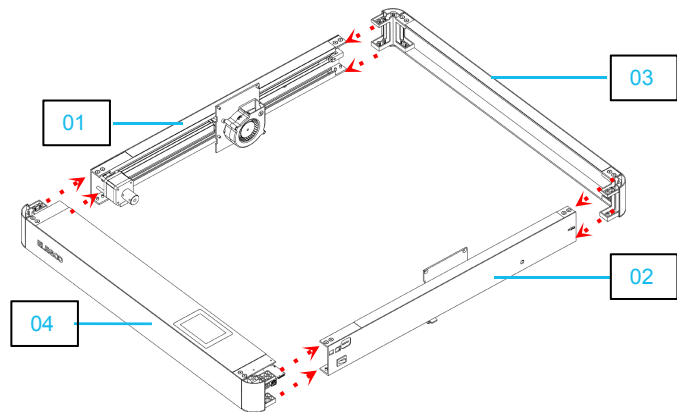

①

- Montare le viti sulle giunzioni.
- Allineare prima le viti ai fori, poi avvitarle.

②

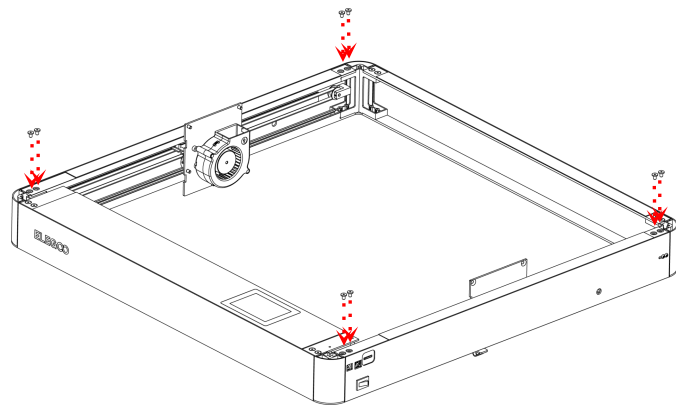

(CM4*6) 8pz

➤ Assemblare le viti al fondo del telaio.

③

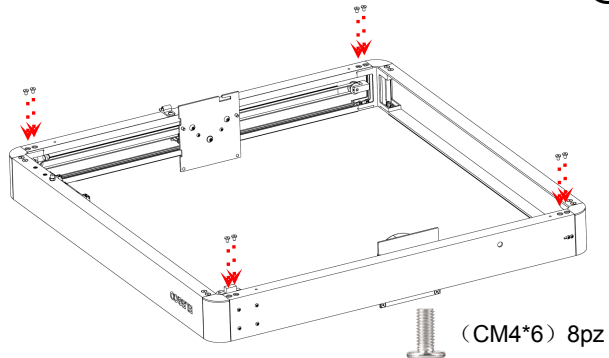

➤ Posizionare e fissare i piedi alla macchina.

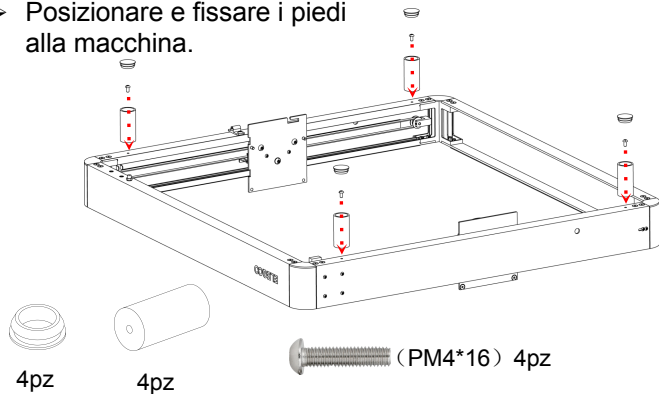

➤ Posizionare e fissare l'assieme dell'asse X.

④

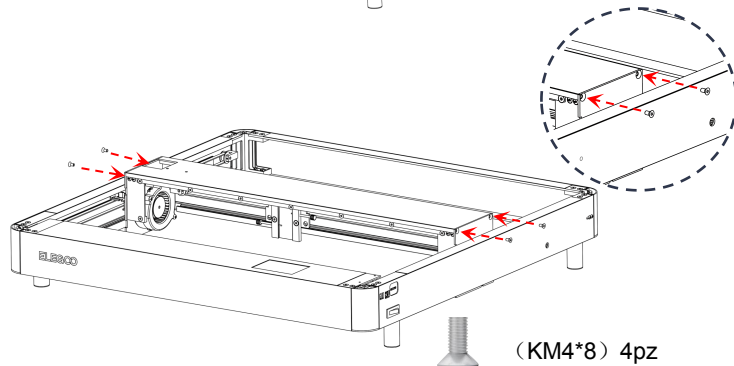
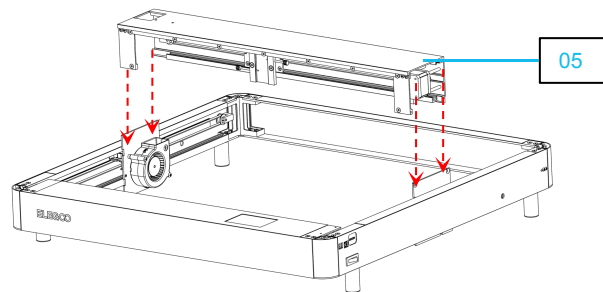

- Allineare i componenti dell'asse X con i rimanenti fori ai lati della protezione. Una volta allineati, stringere le viti per bloccarli.

⑤

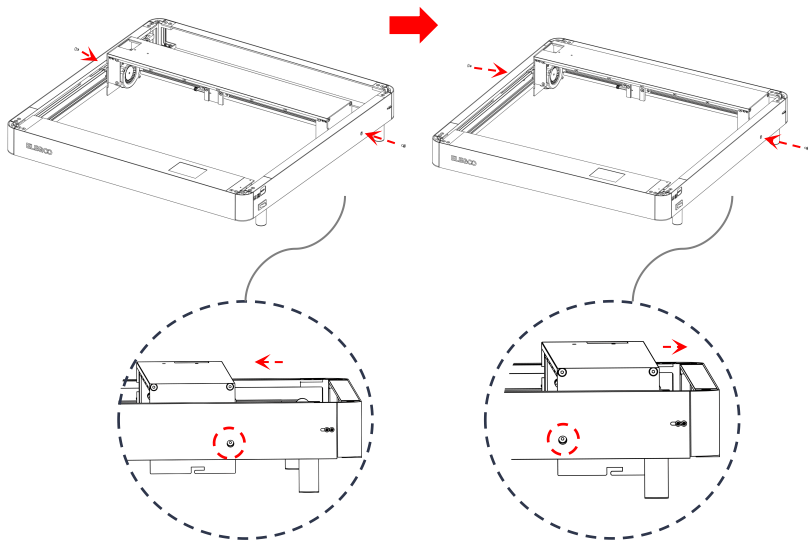

(KM4*8) 4pz

- Installare l'assieme dell'asse X:

⑥

- ① Durante l'installazione, appoggiare l'assieme dell'asse X alla protezione anteriore. (mantenere l'asse X orizzontale)
- ② Far passare la ruota attraverso la cinghia sincrona e fissarla al cuscinetto.
- ③ Connettere il giunto con l'albero motore e stringere le viti per fissarlo. (allentare le viti del giunto per l'installazione)

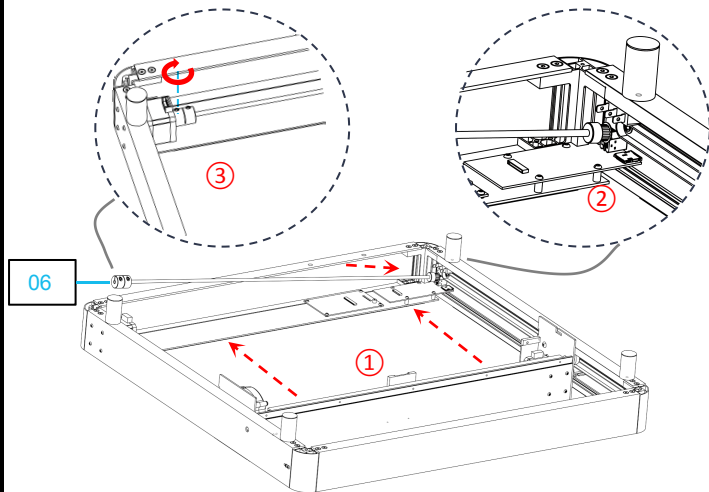

7

➤ Installazione della cinghia di distribuzione:

Inserire la cinghia all' interno della cava con i denti rivolti verso l' alto.

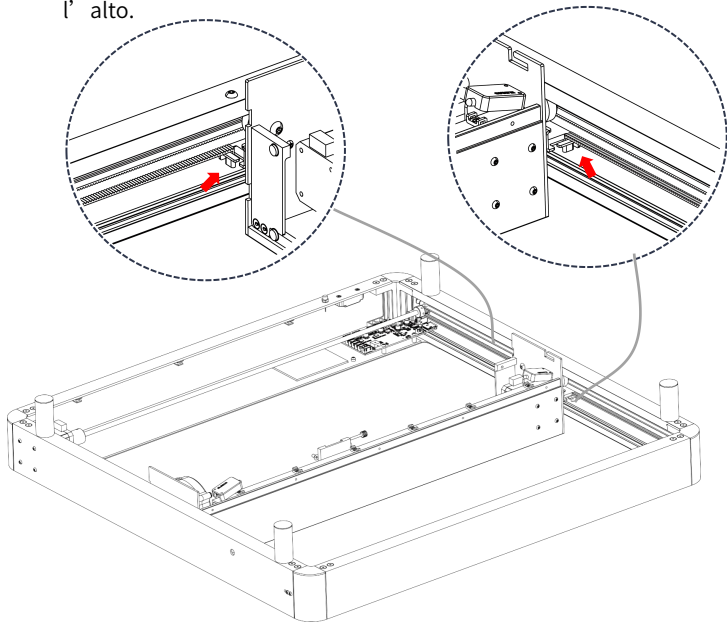

8

➤ Registrazione della cinghia di distribuzione:

Allentare le viti ai lati e spingere il blocchetto di regolazione in modo da tendere la cinghia. Quindi, riavvitare le viti per bloccarlo in posizione.

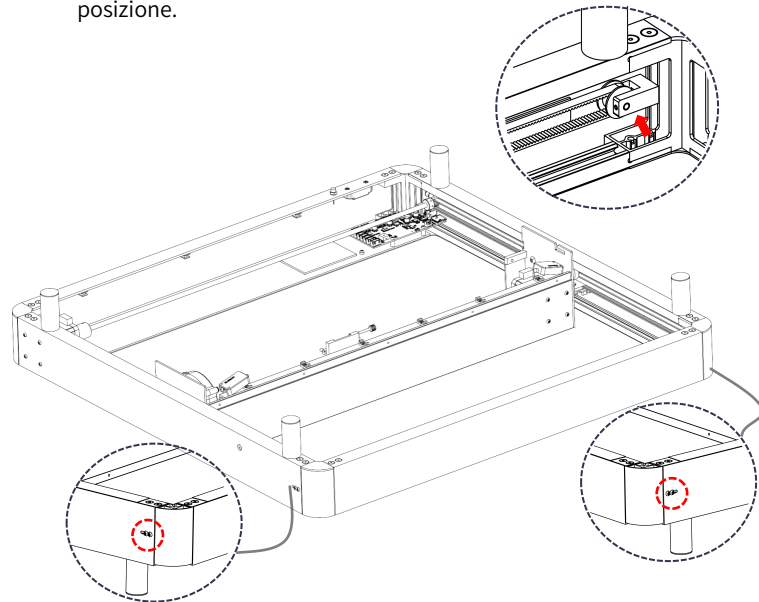

9

- Fissare la piastra di chiusura posteriore

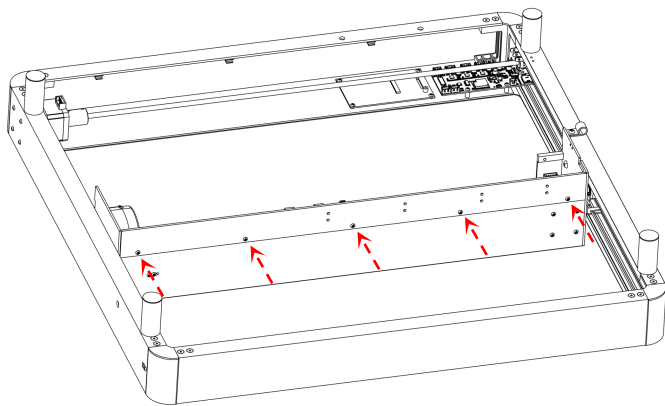

08



(PM3*6) 5pz

10

- Connettere la scheda madre / Installare l'antenna

- Connettere i cavi alla posizione corrispondente seguendo i codici identificativi di ogni cavo.

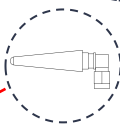
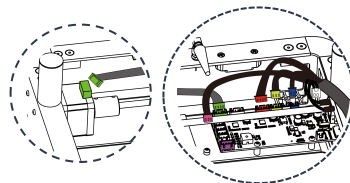
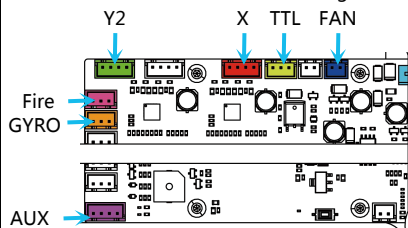

Antenna

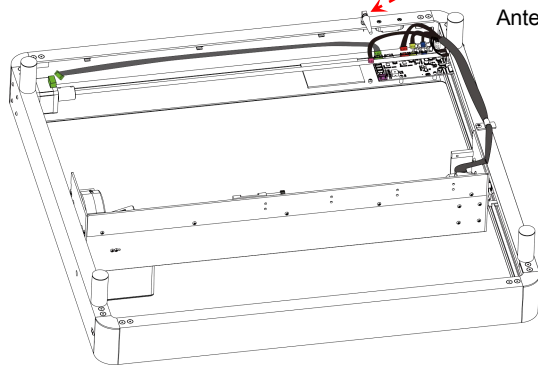

- Cablaggio dell'assieme dell'asse X:

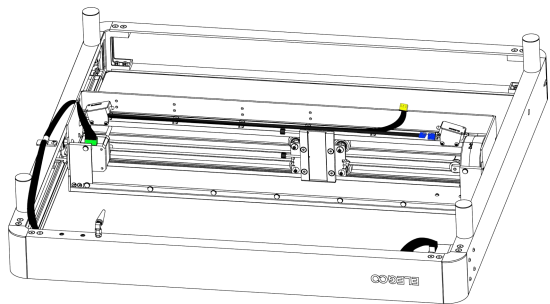

- Connettere la presa del cavo

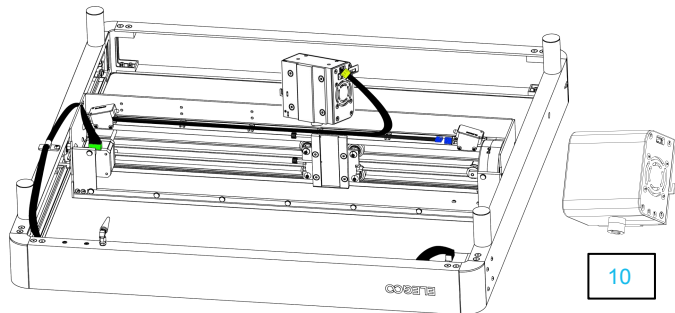

10

11

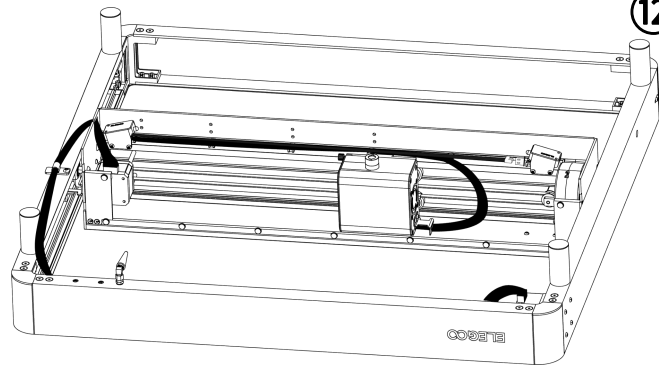

12

- Installazione della testa laser:

Inserire la testa laser nella scanalatura e utilizzare le viti sui lati per bloccarla all'altezza desiderata.

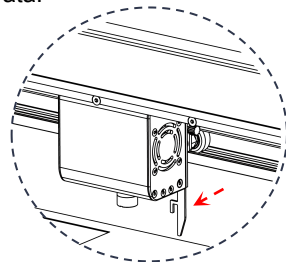
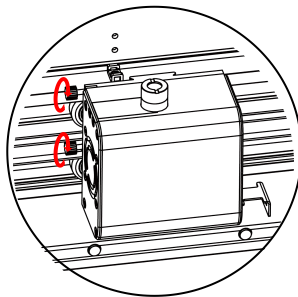

Estrarre l'asta di regolazione della distanza focale e stringere le viti sul lato non appena la testa raggiunge l'altezza a cui l'asta tocca il materiale da incidere.

➤ Installazione del filtro dell'aria

13

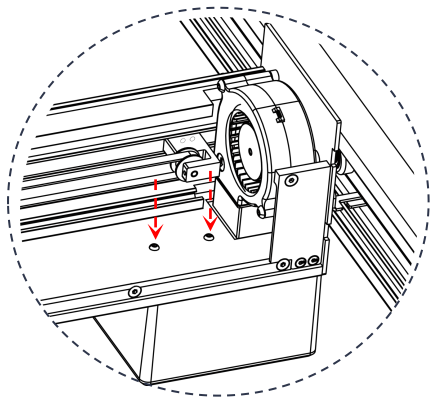

 (PM3*6) 2pz

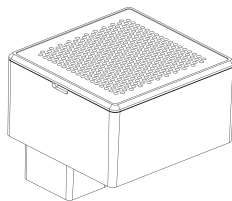

09

➤ Installazione della piastra di chiusura frontale e delle protezioni degli angoli

14

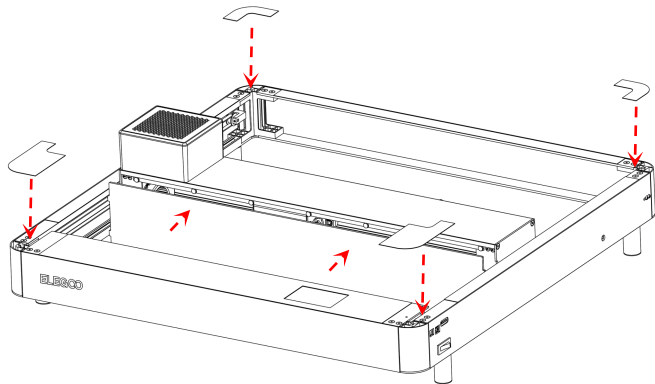

07



1pz

1pz

2pz

Introduzione allo Schermo di Controllo

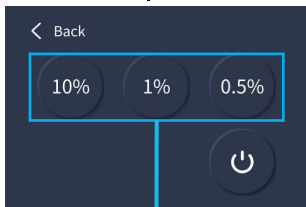
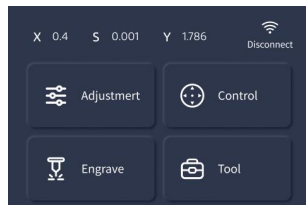

Regolazione della potenza del laser
(Questo valore viene utilizzato durante il
posizionamento della testa)

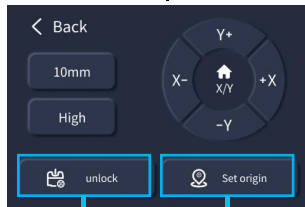

Sblocca lo stato del
motore

Muove la testa del laser alla
posizione specificata per definire
l'origine.

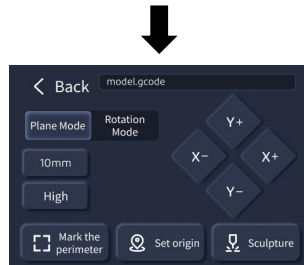
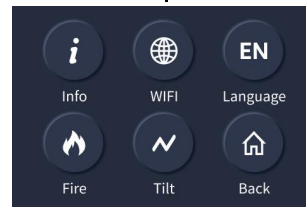
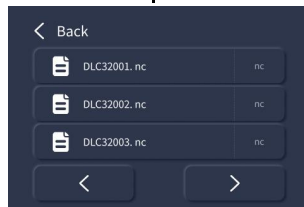

Selezionare il file da incidere,
determinare la posizione del file
tracciandone il perimetro e, infine,
impostare l'origine per l'incisione.

Come Usare la Macchina

Questa macchina è compatibile con diversi programmi sul mercato, come ad esempio LaserGRBL, LighBurn e PHECDA APP. Queste istruzioni operative sono basate sul programma open-source LaserGRBL.

1. Incisione da scheda SD: Salvare il file nella scheda SD effettuando lo slicing nel programma LaserGRBL; selezionare poi il file dallo schermo di controllo per inciderlo.
2. Incisione tramite connessione USB: connettere il computer all'incisore laser tramite un cavo USB e controllare l'incisione laser direttamente dal software LaserGRBL.
3. Incisione da APP: Installare PHECDA APP sul proprio smartphone, connettere lo smartphone al wifi della macchina e inserire l'IP della macchina nell'app. Sarà possibile controllare la macchina con l'app dopo che la connessione è stata stabilita con successo.

①

Incisione da
scheda SD

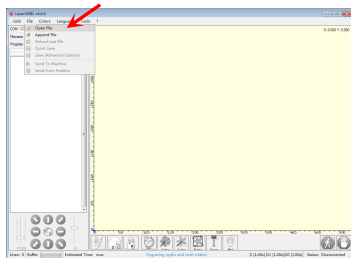

Importare l'immagine
da incidere

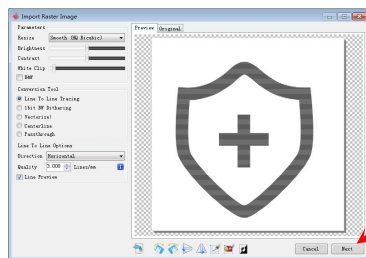

Selezionare il tipo di
incisione

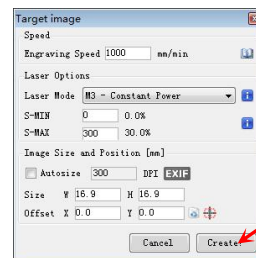

Regolare le dimensioni dell'immagine e i
parametri del laser

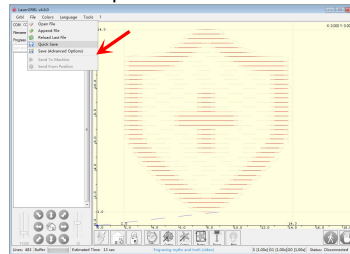
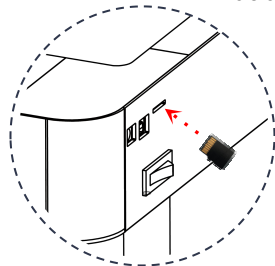

Salvare il file elaborato nella
scheda SD

Posizionare il materiale da incidere

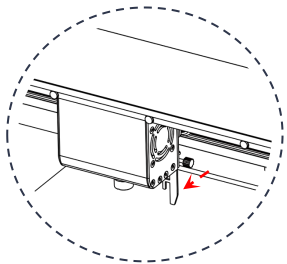
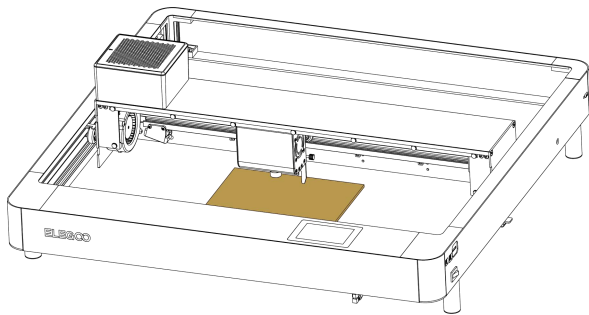

Estrarre l'asta di regolazione della distanza focale e stringere le viti sul lato non appena la testa raggiunge l'altezza a cui l'asta tocca il materiale da incidere.

Fare click per incidere

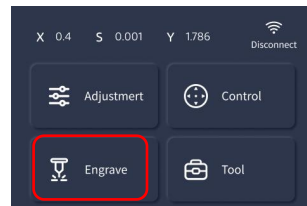

Selezionare il file da incidere

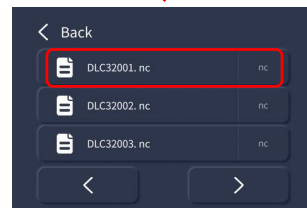

Selezionare Plane Mode →
Set origin → Mark the
Perimeter → confermare la
posizione del perimetro e
infine incidere.



Cercare "PHECDA APP" nel proprio app store e scaricarla

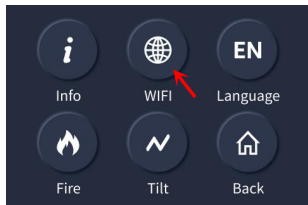

Fare click sul pulsante della macchina per la connessione WiFi

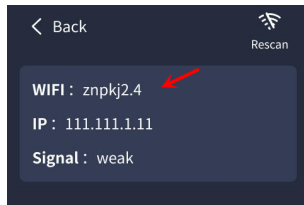

Selezionare Connect

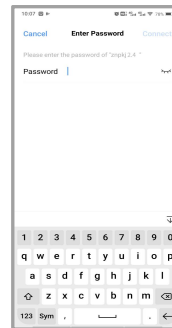

Connettersi al segnale WiFi dal proprio smartphone.

Password preimpostata: 12345678



3

Incisione tramite APP

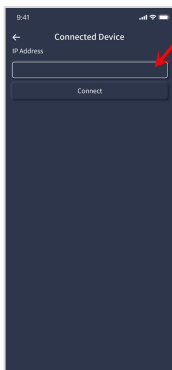

Inserire l'indirizzo IP della macchina per completare la connessione

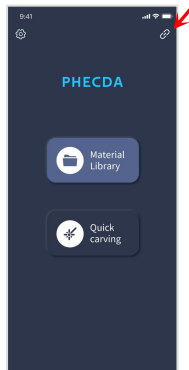

Aprire PHECDA APP sul proprio smartphone e fare click sul pulsante indicato dalla freccia

Nota: Quando si utilizza l'APP  per incidere e tagliare, è necessario inserire la scheda SD, altrimenti non sarà possibile caricare i file da incidere.

Cablaggio della Scheda Madre

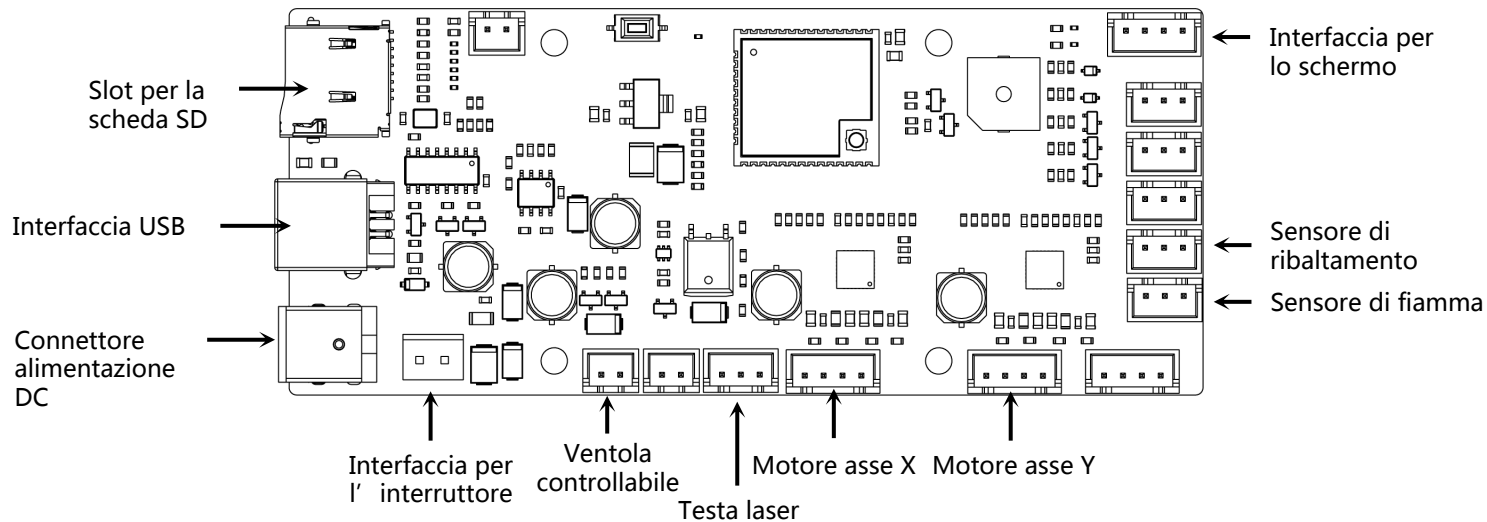

Consigli per la Manutenzione

- Il vetro della testa laser deve essere pulito regolarmente in caso di utilizzo continuato. Dopo un lungo periodo di incisione e taglio, il vetro può portare ad un attraversamento minore di luce a causa della corrosione da parte dei fumi. (Pulire il vetro con etanolo($\geq 75\%$))
- Come rimuovere il vetro:
Il vetro può essere svitato semplicemente inserendo la chiave inglese nell'apposita scanalatura.

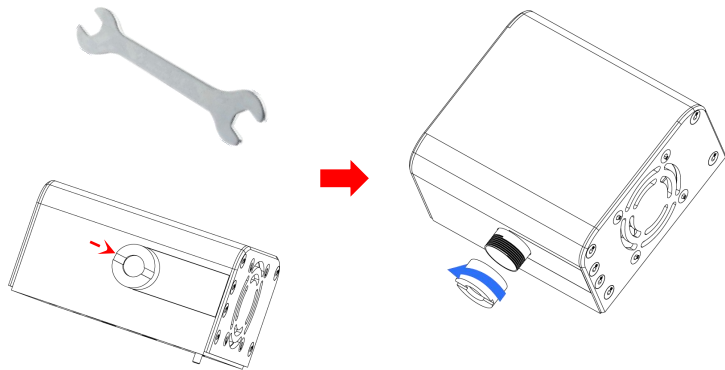

Installazione dell'Air Assist (opzionale)

➤ Componenti

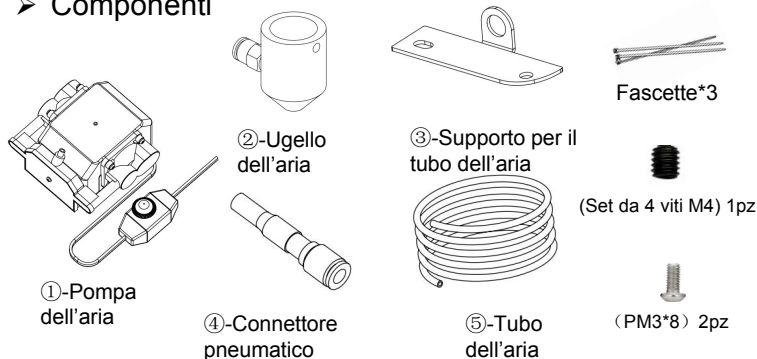

➤ Installazione degli accessori

- Rimuovere le due viti sul lato inferiore sinistro della testa laser.

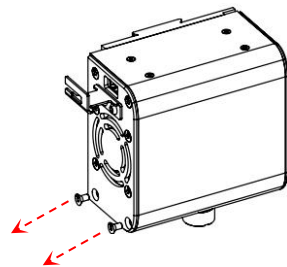

- Installare il supporto per il tubo dell'aria

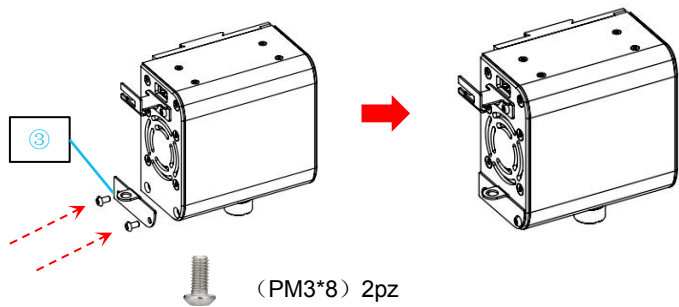

- Installare l'ugello per l'aria

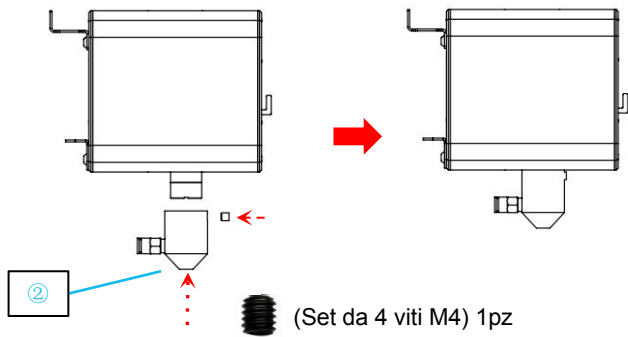

- Inserire il tubo per l'aria nell'ingresso dell'aria sulla testa laser

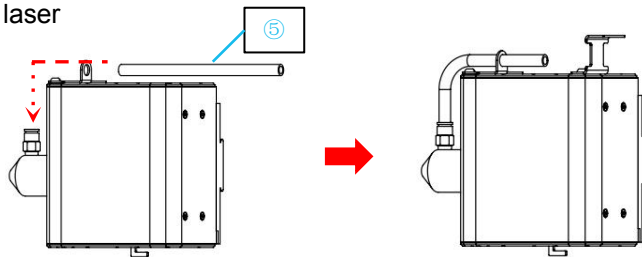

- Inserire il tubo dell'aria nell'uscita dell'aria sulla pompa

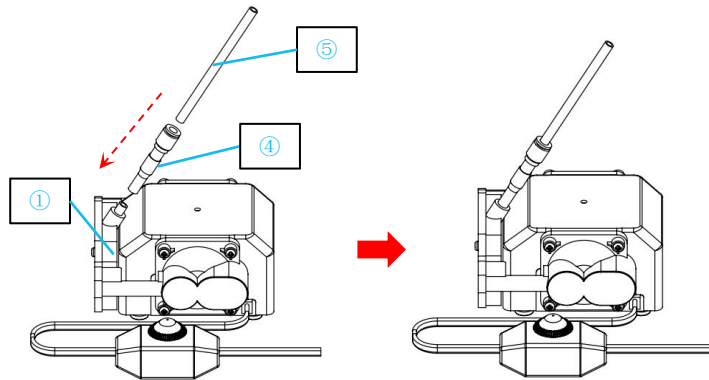

Infine, utilizzare una fascetta per fissare il tubo dell'aria alla testa laser per prevenire il suo danneggiamento durante il funzionamento.

Graveur Laser PHECDA Manuel utilisateur

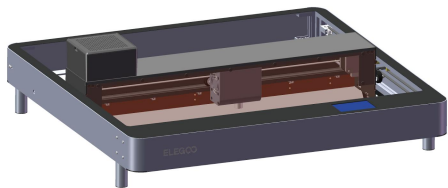

Merci d'avoir choisi Elegoo!

Pour votre commodité, veuillez lire attentivement ce manuel d'instructions avant de l'utiliser.

Les précautions et les conseils contenus dans ce manuel peuvent vous aider à éviter une installation et une utilisation incorrectes.

Si vous avez des questions ou des problèmes qui ne sont pas abordés dans ce manuel, veuillez nous contacter à

l'adresse suivante 3dp@elegoo.com

L'équipe ELEGOO est toujours prête à vous fournir un service de qualité.

Afin de vous offrir une meilleure expérience de nos produits, vous pouvez également en apprendre davantage sur cet équipement de la manière suivante :

1. Le manuel d'instructions : Vous pouvez trouver les instructions d'utilisation et les vidéos sur le fonctionnement de la machine dans la carte SD.

2. Site web officiel d'ELEGOO : www.elegoo.com. Vous pouvez visiter notre site officiel pour trouver les instructions d'utilisation de cette machine et nos coordonnées.

Précautions d'utilisation

- 1) Lors de l'utilisation du graveur laser, veuillez porter des lunettes de protection pour protéger vos yeux.
- 2) Veillez à ce que la zone de travail de la machine soit plane et propre. Les débris accumulés lors de la découpe et de la gravure doivent être nettoyés régulièrement afin d'éviter tout risque d'incendie.
- 3) Ne gravez pas et ne découpez pas de matériaux inconnus, car la vaporisation ou la fusion de nombreux matériaux libère des fumées nocives.
- 4) Ne pas utiliser la machine sans surveillance. Si la machine est mal réglée pour commencer à fonctionner et qu'elle est laissée sans surveillance pendant une longue période, ou si elle subit une défaillance mécanique ou électrique pendant son fonctionnement, elle peut provoquer un incendie.
- 5) Veuillez utiliser la machine dans un endroit bien ventilé afin que la machine puisse évacuer les fumées correctement.
- 6) La machine contient des pièces mobiles à grande vitesse, veillez donc à ne pas vous pincer les mains.
- 7) Effectuez fréquemment la maintenance et nettoyez périodiquement le corps de la machine à l'aide d'un chiffon sec pour éliminer la poussière et les débris lorsque la machine est éteinte.
- 8) Les enfants doivent être surveillés par des adultes lorsqu'ils utilisent la machine afin d'éviter les blessures.
- 9) En cas d'urgence, veuillez éteindre l'appareil directement.

Spécifications machine

Modèle machine : PHECDA			
PHECDA (10W)		PHECDA (20W)	
Puissance tête laser	10W	Puissance tête laser	20W
Epaisseur de coupe max	≤8mm (Contreplaqué)	Epaisseur de coupe max	≤14mm (Contreplaqué)
Puissance machine	55W	Puissance machine	85W
Voltage	100V-240V 50/60Hz	Voltage	100V-240V 50/60Hz
Voltage en sortie	24V	Voltage en sortie	24V
Taille Laser	0.06mm×0.06mm	Taille Laser	0.07mm×0.13mm
Poids	6.5kg	Poids	6.7kg
Principe d'impression	Gravure et découpe Laser	Réglage de la hauteur du laser	0-75mm
Surface de travail	400mm×400mm	Dimensions	673mm×660mm×190mm
Vitesse maximale	X-axis : 25000mm/min Y-axis : 18000mm/min	APP supportée	OUI
Longueur d'onde laser	455±5nm	Options	Module Rotary ; Air Assist
Fonctions auxiliaires	Filtration des fumées, detection de feu, alarme de detection d' inclinaison	Langues	Chinois, anglais, allemand, portugais, espagnol, français, italien
Systèmes compatibles	windows/mac/ios/android	Formats fichiers supportés	SVG/DXF/JPG/JPEG/PNG/BMP/TIF, etc
Matière	Alliage Aluminium	Mode de connexion	USB, Carte SD, APP

Paramètres matériaux

- Plus la vitesse est lente, plus le rapport de puissance de gravure est élevé et plus la profondeur de gravure est importante. Au contraire, plus la vitesse est rapide, plus la puissance de gravure est constante et plus la profondeur de gravure est faible.

Matériau	Operation	10W			20W		
		Vitesse	Temps	Puissance	Vitesse	Temps	Puissance
Contreplaqué (3mm)	Coupe	180mm/min	1	55%	300mm/min	1	55%
	Gravure	12000mm/min	1	95%	12000mm/min	1	65%
MDF (3mm)	Coupe	180mm/min	3	60%	300mm/min	1	100%
	Gravure	12000mm/min	1	80%	12000mm/min	1	55%
Bambou (5mm)	Coupe	300mm/min	5	100%	180mm/min	1	90%
	Gravure	6000mm/min	1	65%	12000mm/min	1	70%
Papier Craft(150g)	Coupe	1800mm/min	1	50%	1800mm/min	1	30%
	Gravure	12000mm/min	1	40%	18000mm/min	1	40%
Acier	Coupe	/	/	/	/	/	/
	Gravure	2000mm/min	1	100%	2000mm/min	1	50%
Carte de visite métallique	Coupe	/	/	/	/	/	/
	Gravure	6000mm/min	1	40%	6000mm/min	1	25%





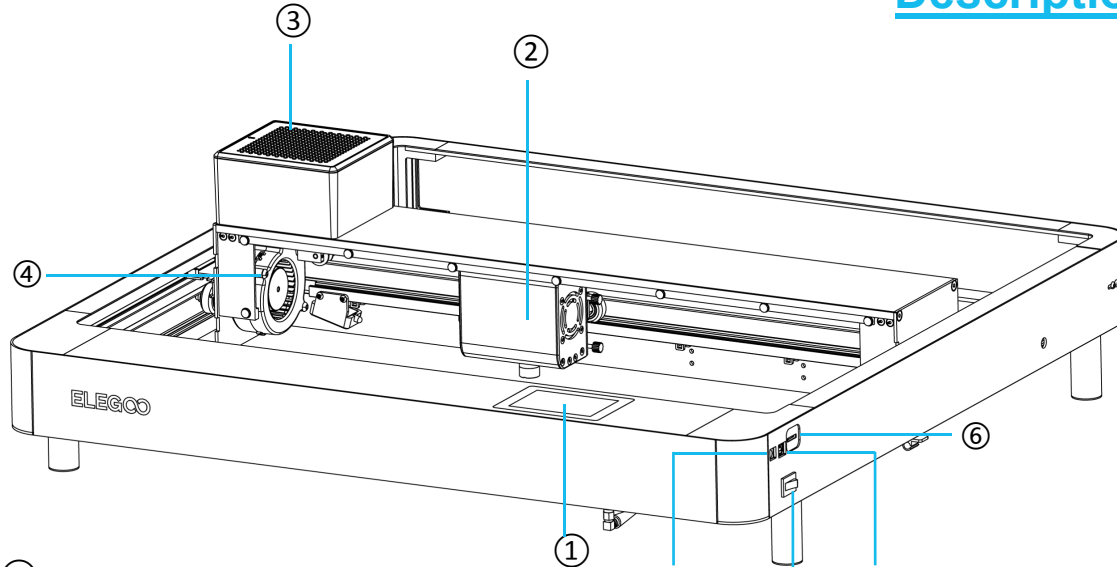







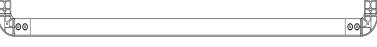



Les données ci-dessus proviennent de tests officiels en laboratoire, et le processus de traitement réel peut varier en raison des différences de matériaux et d'environnements. Les réglages basés sur le test sont uniquement à titre de référence et peuvent être ajustés en fonction de la situation réelle.

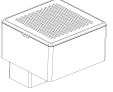



Description machine



- | | | | |
|---|--------------|---|-----------------------|
| ① | Ecran | ⑤ | Port alimentation |
| ② | Tête laser | ⑥ | Port carte SD |
| ③ | Filtre à air | ⑦ | Port USB |
| ④ | Ventilation | ⑧ | Bouton d'alimentation |

Packing List

- 01  Déflecteur gauche
- 02  Déflecteur droit
- 03  Déflecteur arrière
- 04  Déflecteur frontal
- 05  Axe X
- 06  Arbre optique
- 07  Plaque de protection avant
- 08  Plaque de protection arrière
- 09  Filtre à air
- 10  Tête Laser
-  Antenne 1pc
-  1pc
-  2pcs
-  4pcs
-  4pcs
-  4pcs

-  (CM4*6) 16pcs
-  (KM4*8) 8pcs
-  (PM3*6) 7pcs
-  (PM4*16) 4pcs



Lunettes de protection



Cable alimentation

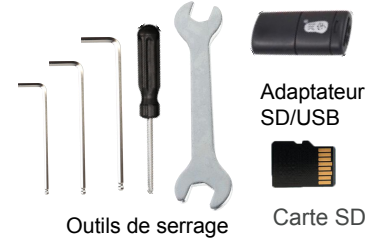

Outils de serrage

Carte SD



Matériaux de gravure



Cable USB

The above accessories shall be subject to actual products, and the pictures are for reference only.

Montage de la machine

①

La machine est livrée avec une carte SD qui contient une video de montage

- Pré-assemblage des quatre pièces sur un plan horizontal.
- Veillez à respecter le sens d'installation des déflecteurs.

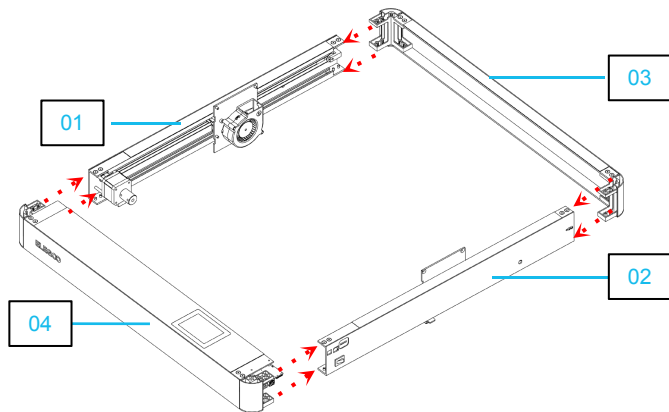

②

- Monter les vis au niveau du joint.
- Alignez d'abord les vis avec les trous, puis serrez les vis..

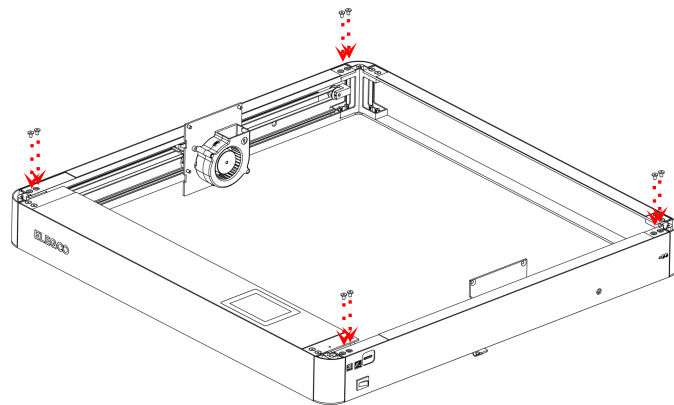

(CM4*6) 8pcs

➤ Mettre les vis sur le dessous de la machine

③

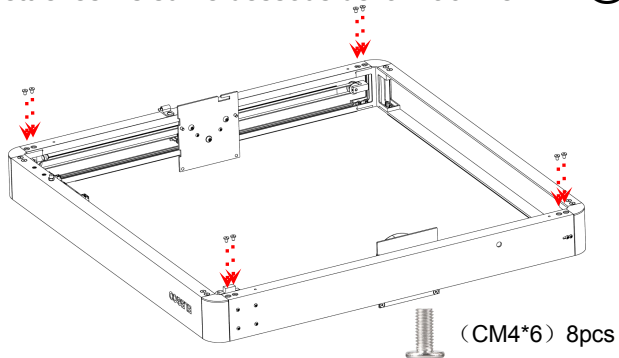

➤ Installer et serrer les pieds de la machine

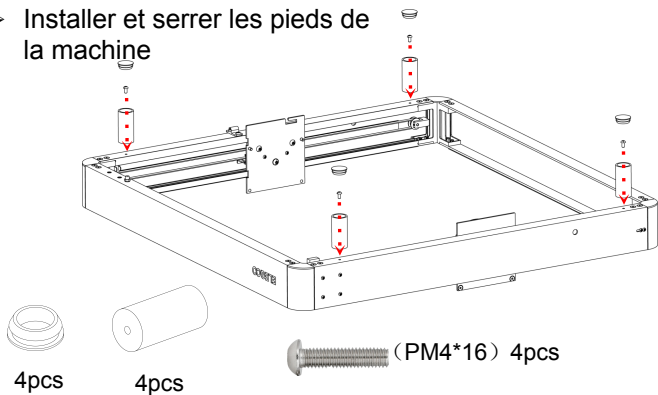

➤ Installer et serrer l'axe X

④

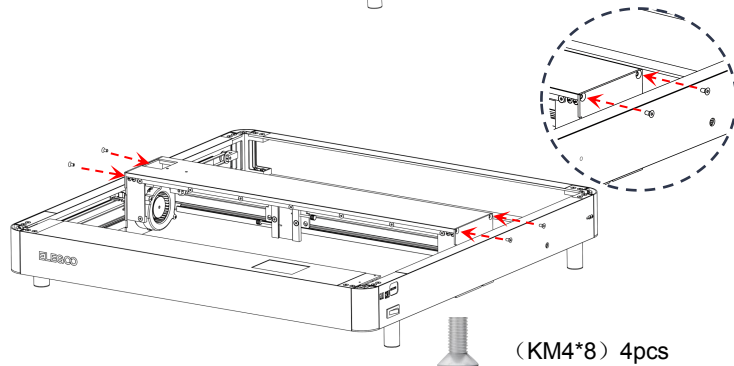
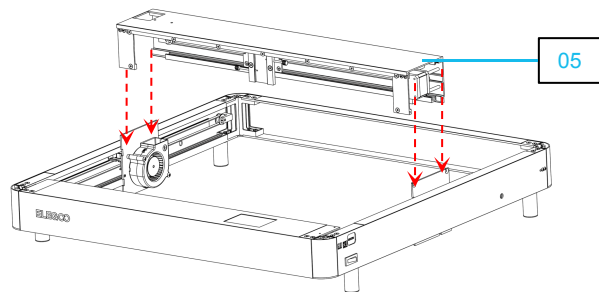

- Alignez les pièces de l'axe X avec les trous restants sur les côtés du déflecteur. Une fois l'alignement réalisé, serrez les vis pour le fixer.

⑤

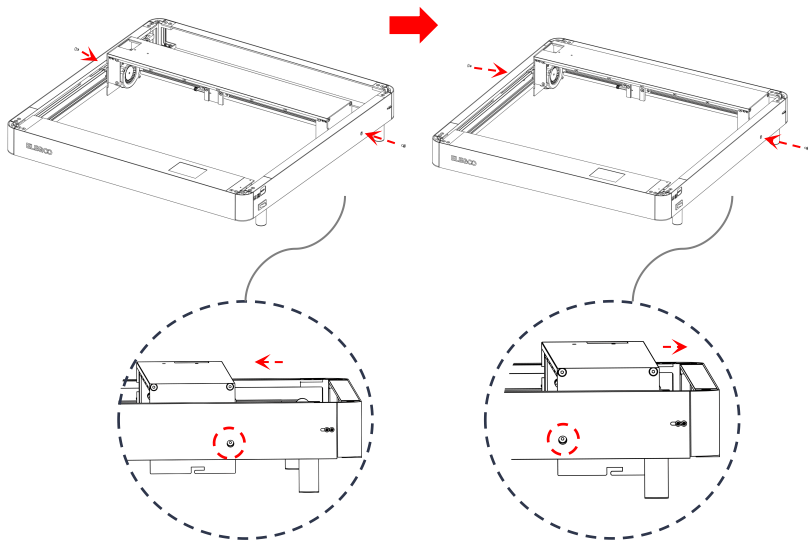

(KM4*8) 4pcs

- Installer l'axe:

⑥

- ① Lors de l'installation, faire glisser l'ensemble de l'axe X contre le déflecteur avant. (maintenir l'axe des X à l'horizontale)
- ② Passer la roue crantée à travers la courroie et la fixer sur le palier.
- ③ Relier l'accouplement à l'arbre du moteur et serrer les vis pour le fixer. (desserrer les vis de l'accouplement lors de l'installation)

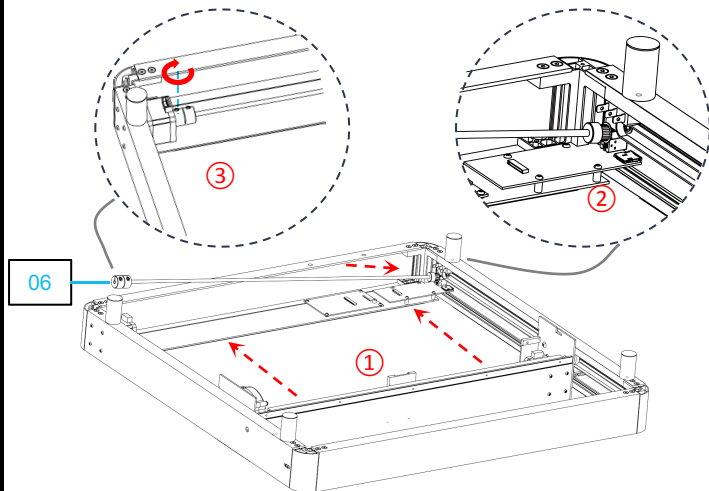

7

➤ Installation de la courroie:

Installer la courroie avec la surface des dents vers le haut de la fente

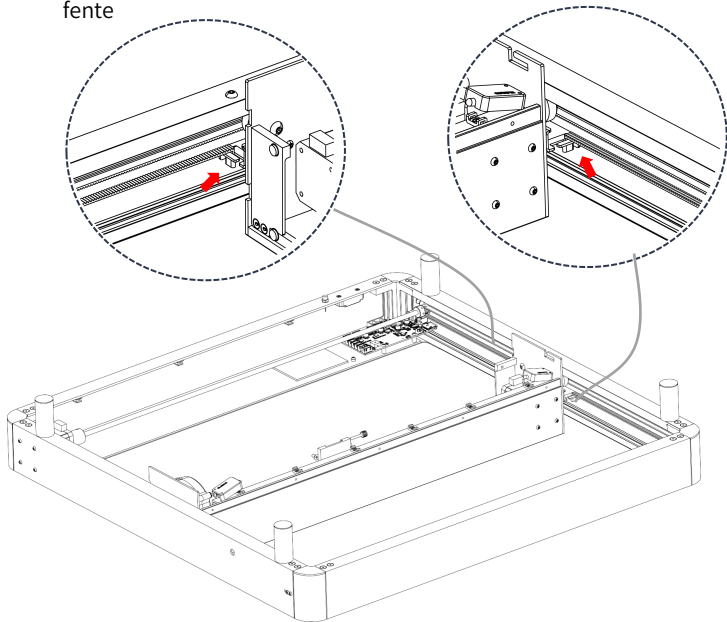

8

➤ Ajustement de la courroie:

Désserrer les vis latérales et serrer le réglage coulissant de la courroie vers une extrémité.

Puis reserrer les vis pour la verrouiller en place

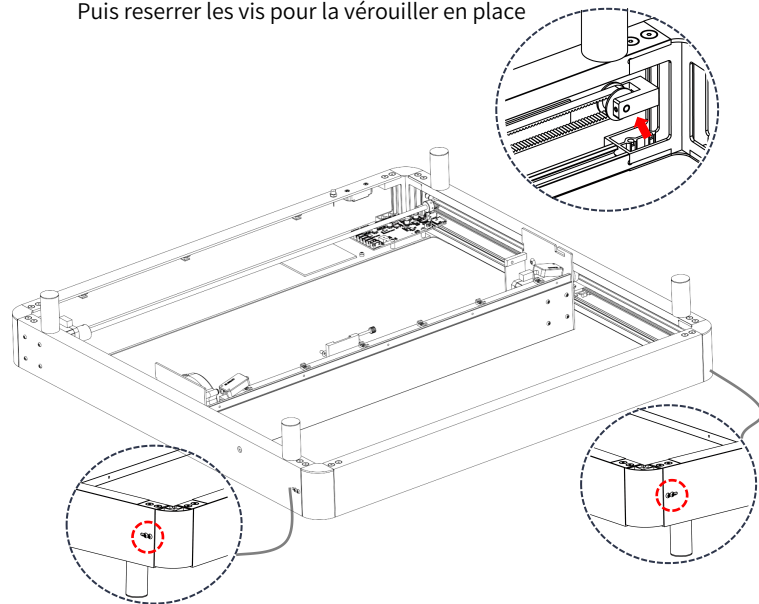

9

➤ Fixer la plaque arrière

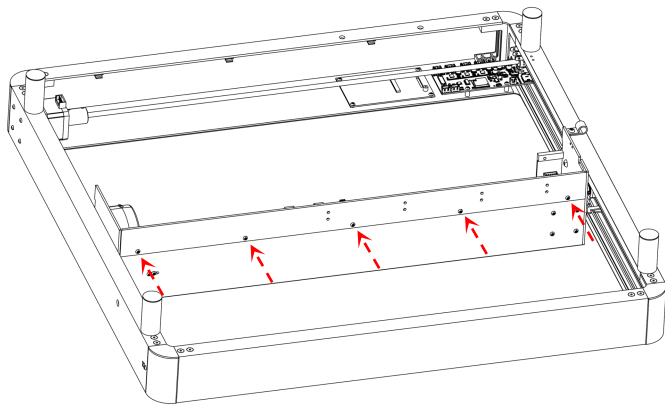

08



(PM3*6) 5pcs

10

➤ Connecter la carte mère et installer l'antenne

➤ Connecter les câbles à l'emplacement correspondant selon le code d'identification.

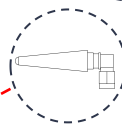
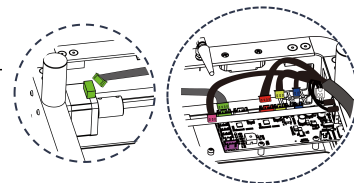
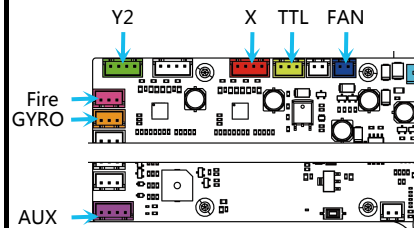

Antenne

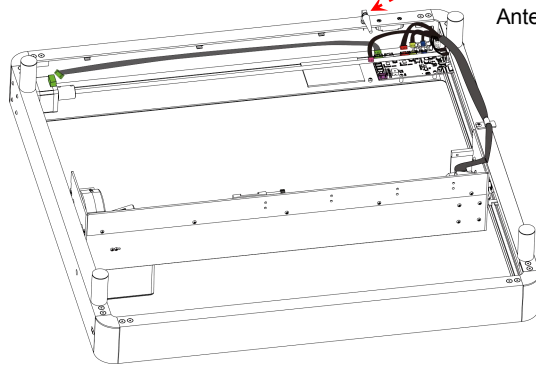

➤ Installation du câblage de l'axe X

11

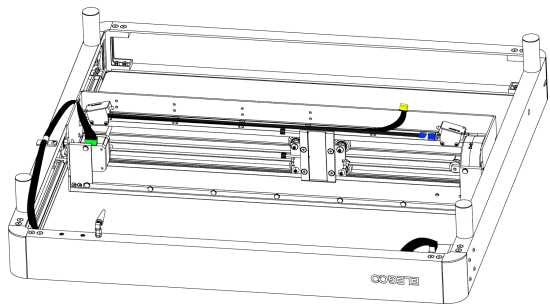

➤ Connexion du câble dans le port prévu

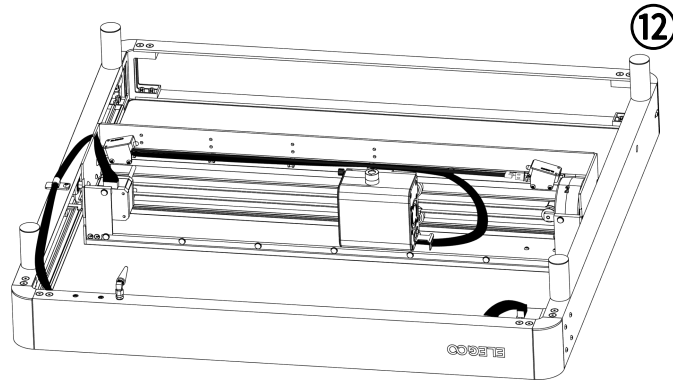
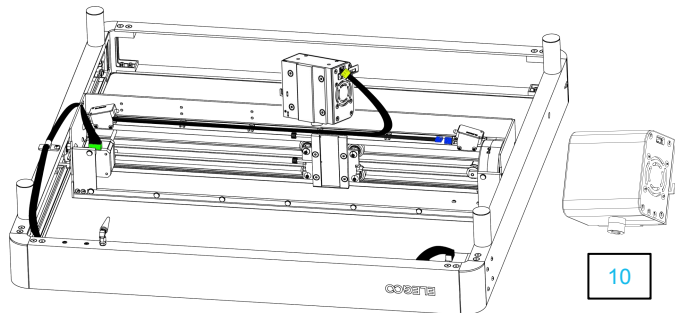

➤ Installation du module laser:

Insérez la tête du laser le long de la rainure et utilisez les vis latérales pour la serrer à la hauteur souhaitée.

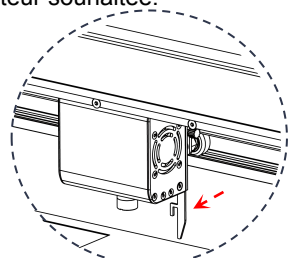
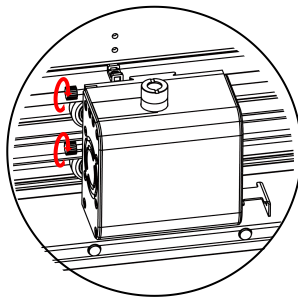

Tirer la barre de réglage de la distance focale et serrer les vis sur le côté à la hauteur où la barre de réglage entre en contact avec le matériau de gravure.

➤ Installation du filtre à air

13

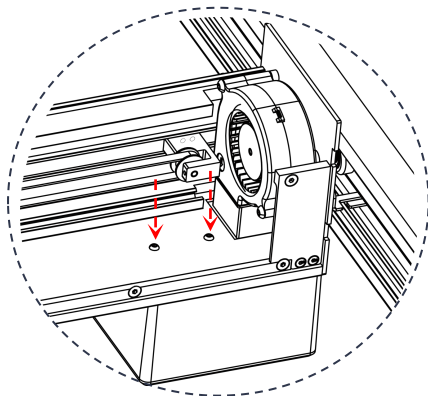

(PM3*6) 2pcs

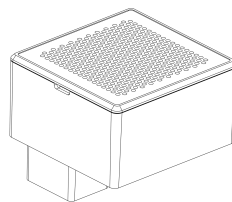

09

➤ Installation de la plaque frontale et des déflecteurs d'angle

14

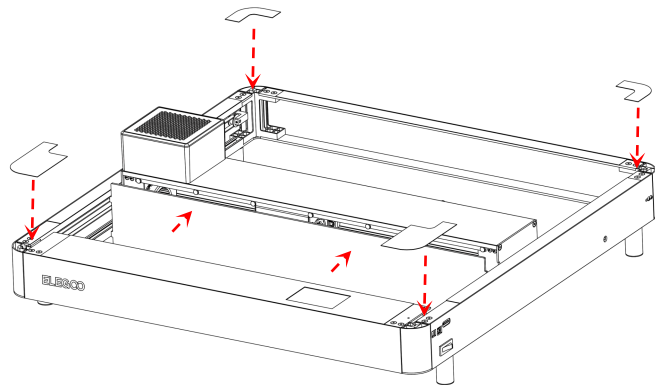

07



1pcs

1pcs

2pcs

Guide des menus de l' écran

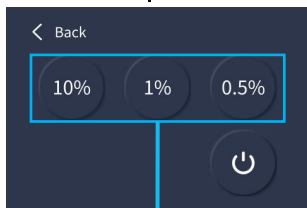
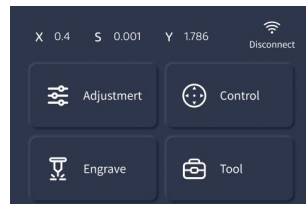

Pourcentage de puissance du laser
(Cette valeur de puissance est utilisée pour
le positionnement)

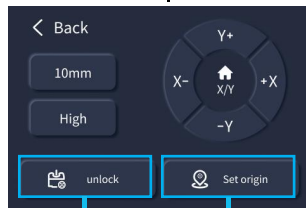

Déverouillage
moteurs

Déplace la tête du laser à la position
initiale définie pour l'identifier

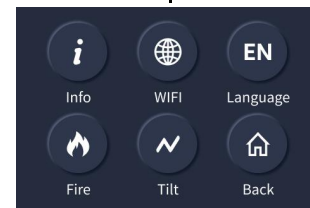
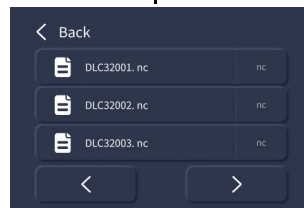

Selection des fichiers à graver,
determine la position de la gravure
par une gravure d'une ligne
périphérique, et ensuite parameter
la position initiale définie de gravure

Comment utiliser la machine?

Cette machine est compatible avec une variété de logiciels sur le marché tels que : LaserGRBL, LightBurn ,et PHECDA APP. Ce mode d'emploi est basé sur le logiciel libre LaserGRBL.

1. Gravure via carte SD : Enregistrez le fichier sur la carte SD en le préparant à l'aide du logiciel LaserGRBL, puis sélectionnez le fichier requis à l'aide de l'écran de contrôle pour le graver.
2. Gravure via connexion USB : Connectez l'ordinateur et le graveur laser à l'aide d'un câble USB, et contrôlez la gravure à l'aide du logiciel LaserGRBL.
3. Gravure via l'APP : Installez l'application PHECDA APP sur votre téléphone portable, connectez votre téléphone portable au wifi de la machine, entrez l'IP de la machine dans l'application, et vous pouvez utiliser la machine après une connexion réussie.

①

Graver via carte SD

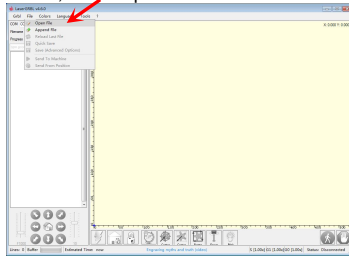

Importer l'image souhaitée

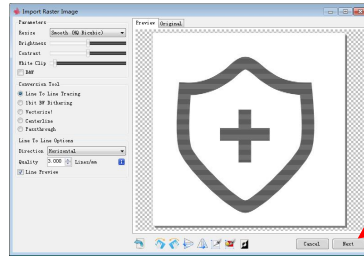

Sélectionner le mode de gravure

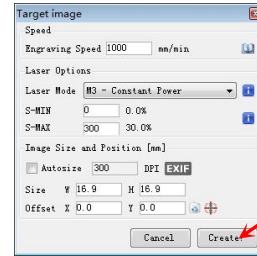

Ajuster la taille de l'image et les paramètres

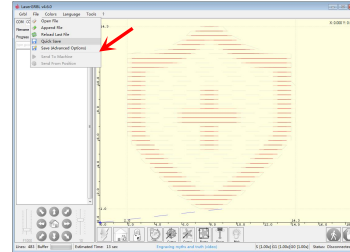
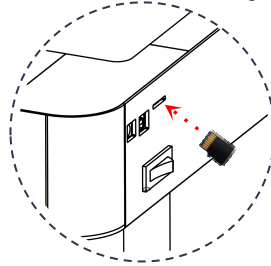

Sauvegarder le fichier sur la carte SD

Placez le matériau à graver

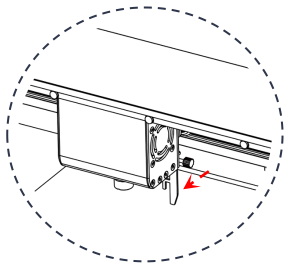
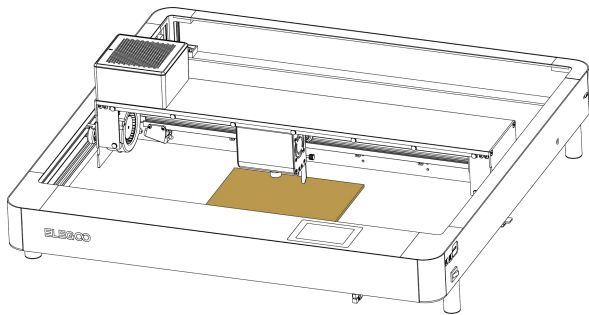

Tirer la barre de réglage de la distance focale et serrer les vis sur le côté à la hauteur où la barre de réglage entre en contact avec le matériau de gravure.

Cliquez sur
"Engrave"

Sélectionner le
fichier de gravure

Sélectionner "Plane Mode" → ①
sélectionner l'origine du jeu
→ marquer le périmètre →
confirmer et graver

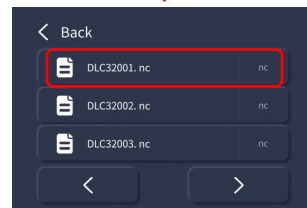
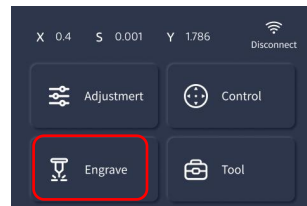

Allumez le graveur laser, connectez-le à l'ordinateur via le câble USB, double-cliquez pour ouvrir le logiciel de gravure, cliquez sur le bouton de connexion, et les données affichées prouvent que la connexion a réussi. (Note : vous ne pouvez pas ouvrir plus d'un logiciel de tranchage en même temps, car il peut y avoir des conflits, et le port ne peut pas être connecté s'il est occupé.)

②
Graver via
USB

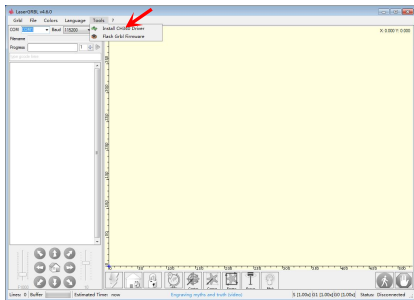

Si la connexion USB ne répond pas,
installer le Driver CH340 via le logiciel

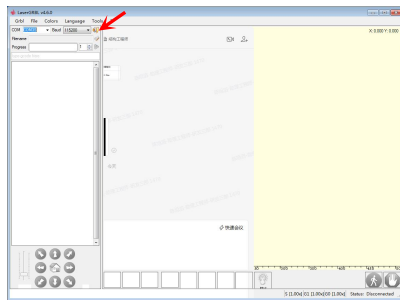

Cliquez sur
"connect"

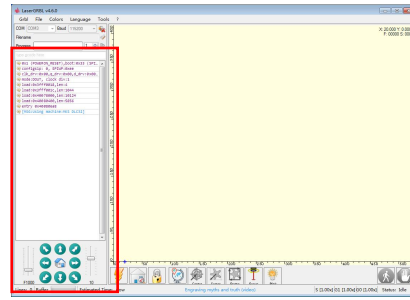

La connexion est établie si les données sont
affichées

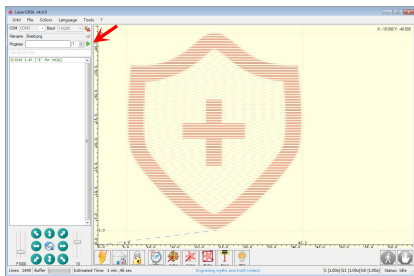

Lancez le programme via le
bouton de démarrage

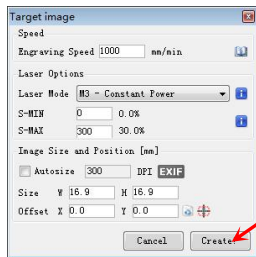

Ajustez la taille de l'image et
les paramètres de la machine

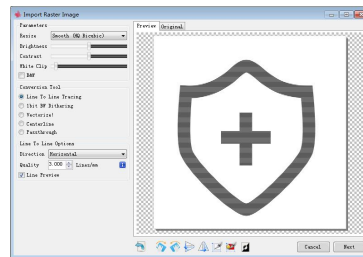

Importez l'image souhaitée

Chercher "PHECDA APP" dans votre magasin d'applications mobile de téléchargement

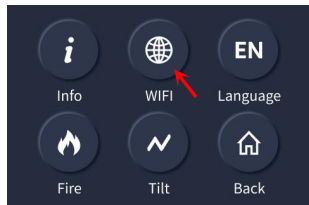

Cliquer sur le bouton de connection "WIFI"

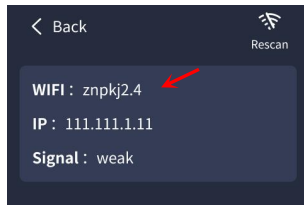

Selectionner "Connect"

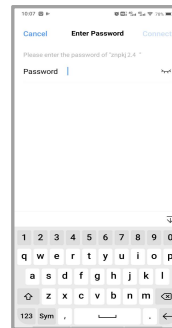

Se connecter au signal WIFI sur votre appareil
Mot de passe de base: 12345678

3

Graver via l'APP

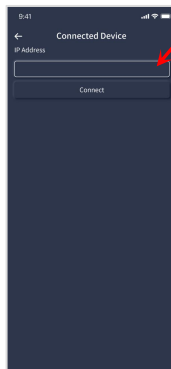

Entrer l'adresse IP de la machine pour établir une connexion

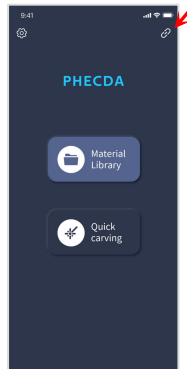

Ouvrir PHECDA APP sur votre mobile et cliquer sur le bouton indiqué par la flèche

Note: Lorsque vous utilisez  l'application pour graver ou découper, vous devez insérer la carte SD au préalable, sinon les fichiers de gravures ne pourront pas être chargés.

Branchements de la carte mère

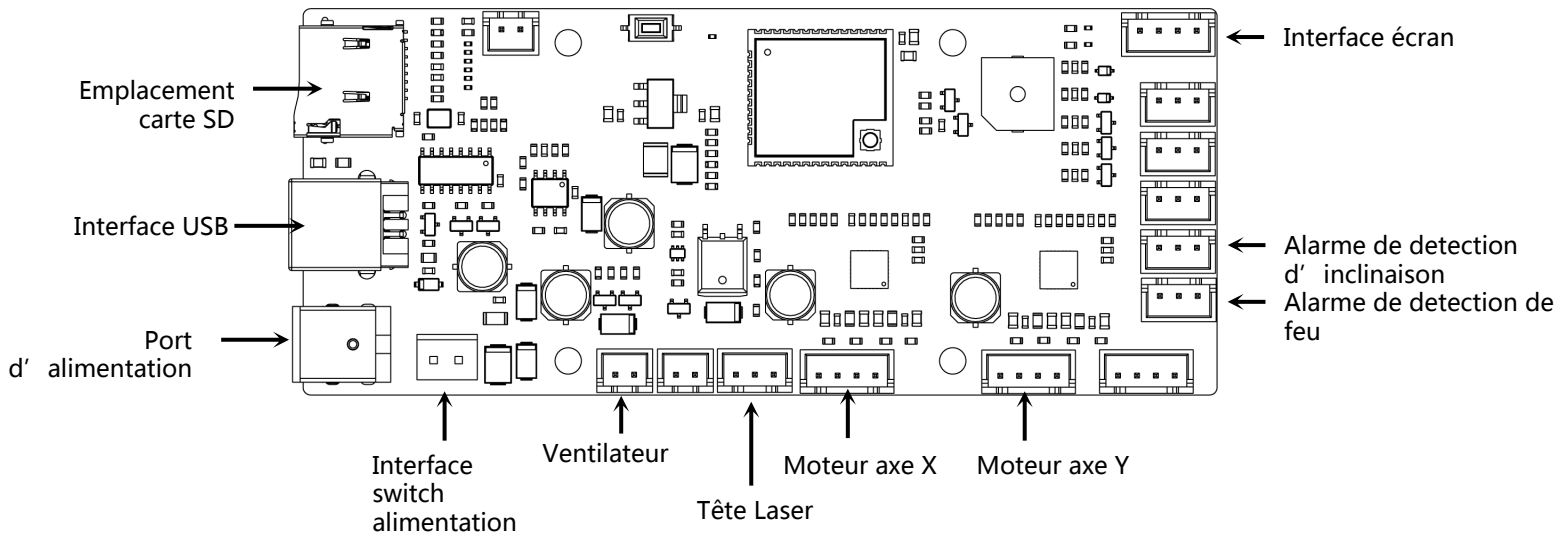

Maintenance

- La fenêtre du miroir de la tête du laser doit être nettoyée régulièrement pour assurer une bonne durabilité. Après une longue période d'utilisation en coupe et de gravure, la fenêtre du miroir peut entraîner une perte d'efficacité du laser cause par la corrosion des fumées (nettoyer cet élément avec de l'éthanol($\geq 75\%$)).
- Pour le démonter, utiliser la clé fournie et déserrer grâce aux méplats prévus à cet effet.

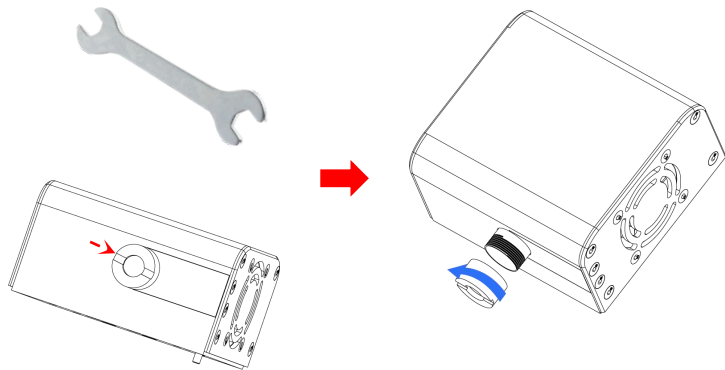

Installation du Air Assist (optionnel)

➤ Liste des pièces

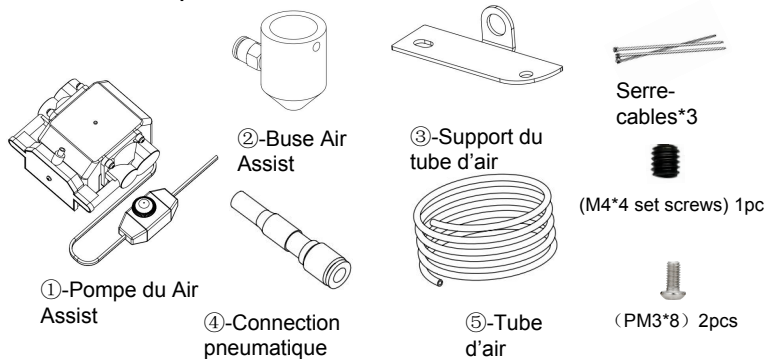

➤ Installation de l'accessoire

- Retirer les deux vis du bas sur le côté gauche du module laser.

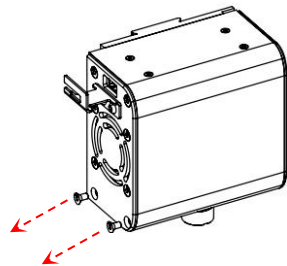

- Installer le support du tube d'air

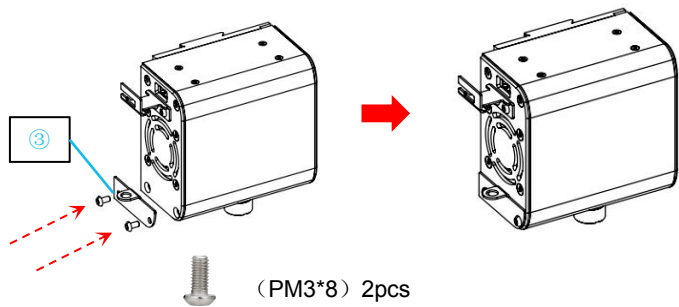

- Installer la buse du Air Assit au module laser

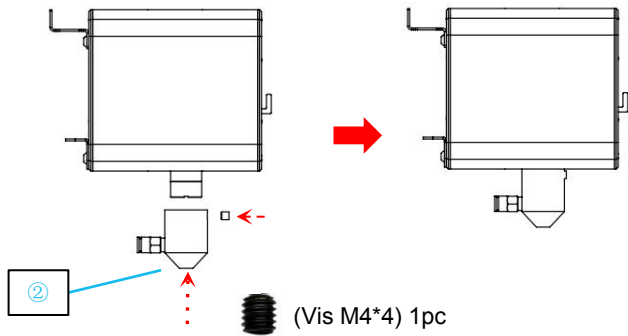

- Insérer l'extrémité du tube d'air sur la connexion de la buse

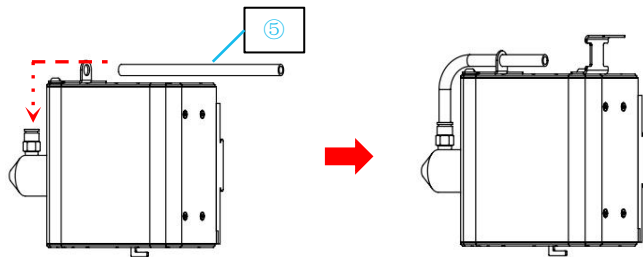

- Insérer le tube d'air au niveau de la connexion à la pompe

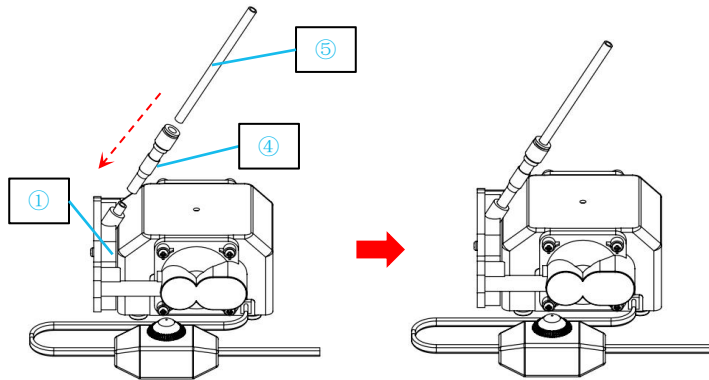

Pour terminer utiliser un serre-cable pour fixer le tube d'air et le câble du laser ensemble pour éviter tout dommage sur le tube durant l'utilisation.

PHECDA Laser-Gravierer Benutzerhandbuch

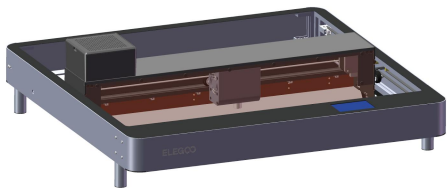

Vielen Dank, dass Sie sich für Produkte von ELEGOO entschieden haben!

Bitte lesen Sie diese Bedienungsanleitung sorgfältig, bevor Sie das Produkt verwenden. Die Vorsichtsmaßnahmen und Tipps in dieser Anleitung können Ihnen helfen, eine falsche Installation und Verwendung zu vermeiden.

Bei Fragen oder Problemen, die in dieser Anleitung nicht behandelt werden, kontaktieren Sie uns bitte unter folgender E-Mail-Adresse: 3dp@elegoo.com

Das ELEGOO-Team ist immer bereit, Ihnen qualitativ hochwertigen Service zu bieten.

Um Ihnen ein besseres Benutzererlebnis mit unseren Produkten zu bieten, können Sie auf folgende Weise mehr über dieses Gerät erfahren:

1. Das Benutzerhandbuch: Sie finden alle relevanten Anweisungen und Videos zur Bedienung des Geräts auf der mitgelieferten TF-Karte.
2. Offizielle ELEGOO-Website: www.elegoo.com. Sie können unsere offizielle Website besuchen, um alle relevanten Betriebsanweisungen für das Gerät und unsere Kontaktinformationen zu finden.

Sicherheitshinweise

1. Beim Betrieb des Lasergravierers muss eine Laser-Sicherheitsbrille getragen werden, um Verletzungen der Augen auszuschließen.
2. Bitte halten Sie den Arbeitsbereich des Geräts flach und sauber. Abfall, der beim Schneiden und Gravieren anfällt, sollte regelmäßig beseitigt werden, um Brandgefahren zu vermeiden.
3. Gravieren oder schneiden Sie keine unbekanntem Materialien, da die Verdampfung oder das Schmelzen vieler Materialien schädliche Dämpfe freisetzen und zu Verletzungen führen kann.
4. Bitte lassen Sie das Gerät nicht unbeaufsichtigt. Wenn das Gerät fälschlicherweise gestartet wird und unbeaufsichtigt bleibt, oder einen mechanischen oder elektrischen Defekt aufweist, kann dies einen Brand verursachen.
5. Bitte betreiben Sie die Maschine in einem gut belüfteten Bereich, damit das Gerät Dämpfe ordnungsgemäß abführen kann.
6. Achten Sie darauf, Ihre Hände nicht in den Bereich der schnell beweglichen Teile zu bringen, um Verletzungen zu vermeiden.
7. Bitte führen Sie regelmäßig Wartungen durch und reinigen Sie das Gerät mit einem trockenen Tuch, um Staub und Abfall zu entfernen, während das Gerät ausgeschaltet ist.
8. Bitte stellen Sie sicher, dass Kinder beim Benutzen des Geräts von einem Erwachsenen beaufsichtigt werden, um Verletzungen zu vermeiden.
9. Bei Fehlverhalten ist das Gerät direkt von der Stromversorgung zu trennen.

Modell: PHECDA			
PHECDA (10W)		PHECDA (20W)	
Laserleistung	10W	Laserleistung	20W
Maximale Schnitttiefe	≤8mm (Lindenholzplatte)	Maximale Schnitttiefe	≤14mm (Lindenholzplatte)
Geräteleistung	55W	Geräteleistung	85W
Nennspannung	100V-240V 50/60Hz	Nennspannung	100V-240V 50/60Hz
Ausgangsspannung	24V	Ausgangsspannung	24V
Lasergröße	0.06mm×0.06mm	Lasergröße	0.07mm×0.13mm
Nettogewicht	6.5kg	Nettogewicht	6.7kg
Druckprinzip	Lasergravur- und schneiden	Laserkopfhöhe	0-75mm
Gravierbereich	400mm×400mm	Gerätegröße	673mm×660mm×190mm
Maximale Graviergeschwindigkeit	X-Achse : 25000mm/min Y-Achse : 18000mm/min	App-Unterstützung	Ja
Laserwellenlänge	455±5nm	Zubehörteile	Drehvorrichtung, Air Assist
Zusatzfunktionen	Rauchfiltration, Flammenmelder, Neigungserkennungsalarm	Unterstützte Sprachen	Chinesisch, Englisch, Deutsch, Portugiesisch, Spanisch, Französisch, Italienisch
Unterstützte Betriebssysteme	Windows/Mac/iOS/Android	Unterstützte Dateiformate	SVG/DXF/JPG/JPEG/PNG/BMP/TIF, etc.
Produktmaterial	Aluminiumlegierung	Schnittstellen	TF-Karte, USB, App

Material Einstellungen

- Je langsamer die Geschwindigkeit, desto höher muss das Verhältnis der Gravurleistungseinstellung sein und desto tiefer wird die Gravurtiefe. Im Gegenteil, je schneller die Geschwindigkeit, desto konstanter ist die Gravurleistung und desto flacher ist die Gravurtiefe.





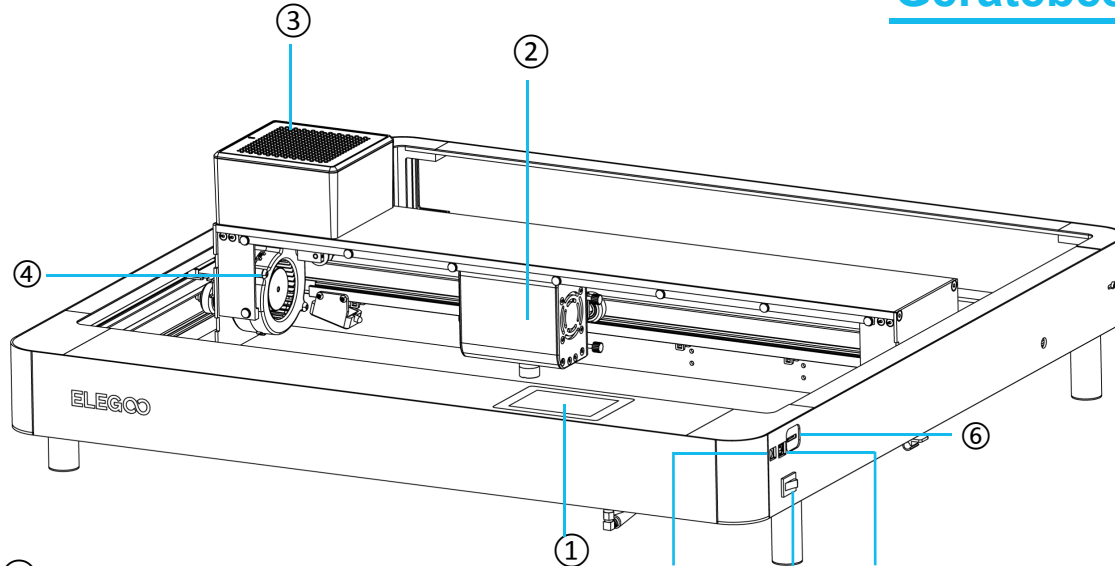





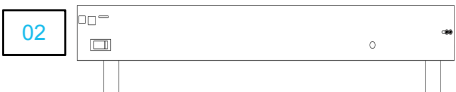



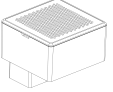

Graviermaterial	Vorgang	10W			20W		
		Geschwindigkeit	Zeit	Leistung	Geschwindigkeit	Zeit	Leistung
Lindenholz-, Sperrholzplatte (3mm)	schneiden	180mm/min	1	55%	300mm/min	1	55%
	gravieren	12000mm/min	1	95%	12000mm/min	1	65%
MDF (3mm)	schneiden	180mm/min	3	60%	300mm/min	1	100%
	gravieren	12000mm/min	1	80%	12000mm/min	1	55%
Bambusplatte (5mm)	schneiden	300mm/min	5	100%	180mm/min	1	90%
	gravieren	6000mm/min	1	65%	12000mm/min	1	70%
Kraftpapier (150g)	schneiden	1800mm/min	1	50%	1800mm/min	1	30%
	gravieren	12000mm/min	1	40%	18000mm/min	1	40%
Rostfreier Stahl	schneiden	/	/	/	/	/	/
	gravieren	2000mm/min	1	100%	2000mm/min	1	50%
Metallvisitenkarte	schneiden	/	/	/	/	/	/
	gravieren	6000mm/min	1	40%	6000mm/min	1	25%





Die oben genannten Daten stammen aus offiziellen Laboruntersuchungen, der tatsächliche Verarbeitungsprozess kann aufgrund von Unterschieden in Materialien und Umgebungen variieren. Die Einstellungen, die auf dem Test basieren, dienen nur als Referenz und können je nach tatsächlicher Situation angepasst werden.



- | | | | |
|---|--------------|---|---------------|
| ① | Bedienfeld | ⑤ | DC-Buchse |
| ② | Laserkopf | ⑥ | TF-Kartenslot |
| ③ | Luftfilter | ⑦ | USB-Buchse |
| ④ | Objektlüfter | ⑧ | Hauptschalter |

Packing List

-  01 Linke Blende
-  02 Rechte Blende
-  03 Hintere Blende
-  04 Vordere Blende
-  05 X-Achsen-Einheit
-  06 Optischer Schaft
-  07 Vordere Abdeckplatte
-  08 Hintere Abdeckplatte
-  09 Luftfilter
-  10 Laserkopf
-  Antenne
-  1pc
-  1pc
-  2pcs
-  4pcs
-  4pcs
-  4pcs
-  4pcs

-  (CM4*6) 16stk.
-  (KM4*8) 8stk.
-  (PM3*6) 7stk.
-  (PM4*16) 4stk.



Das oben genannte Zubehör bezieht sich auf tatsächliche Produkte und die Bilder dienen nur zur Referenz.

Montage des Geräts

①

Das Gerät wird mit einer TF-Karte geliefert, auf der ein Video zur Montage enthalten ist.

- Legen sie die Vier vormontierten Teile auf eine ebene Fläche
- Bitte achten Sie auf die Ausrichtung der Blenden bei der Montage.

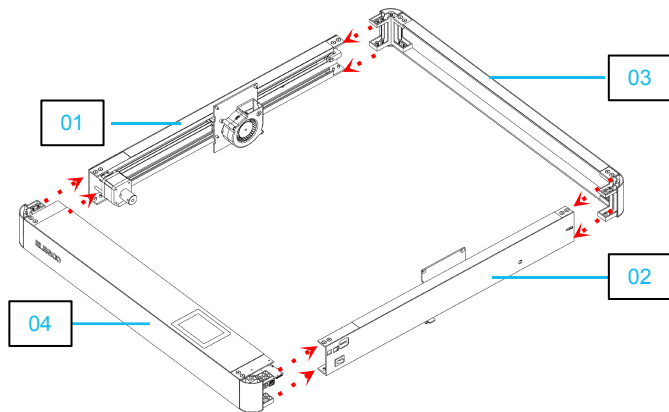

②

- Befestigen Sie die Schrauben an den Verbindungsstellen.
- Setzen Sie zuerst alle Schrauben in die Löcher ein und ziehen Sie sie anschließend fest.

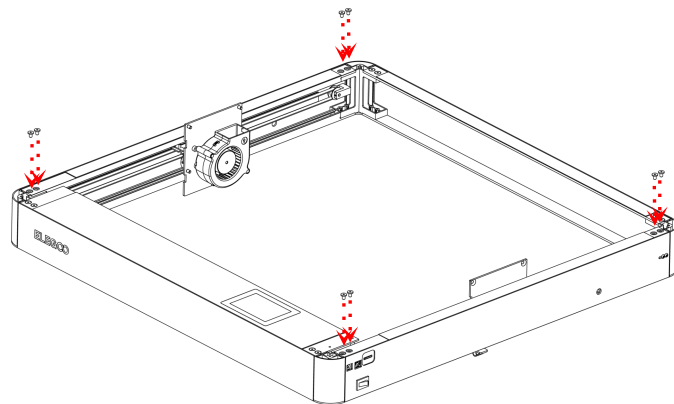

(CM4*6) 8stk.

- Setzen Sie zuerst alle Schrauben der Unterseite in die Löcher ein und ziehen Sie sie anschließend fest. ③

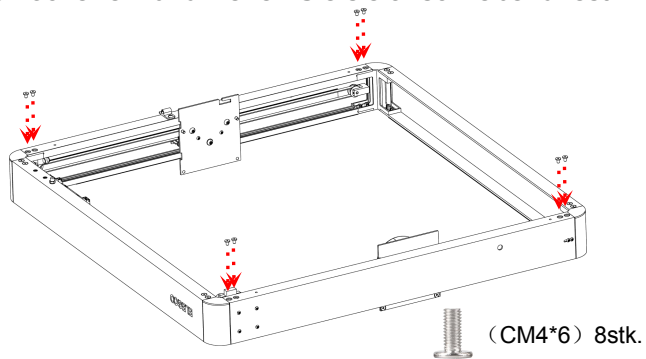

- Montieren Sie die Standfüße und fixieren Sie sie anschließend.

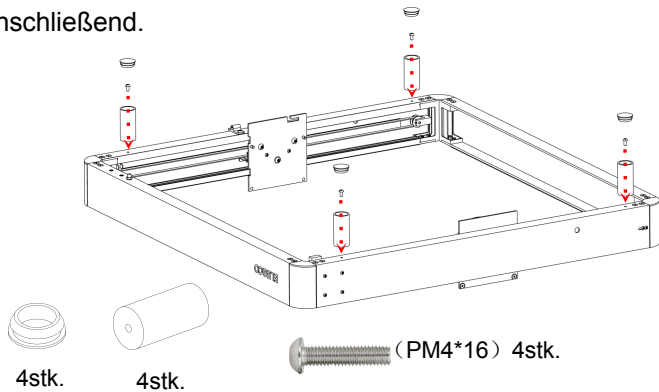

- Montieren Sie die X-Achsen-Einheit und fixieren Sie sie anschließend. ④

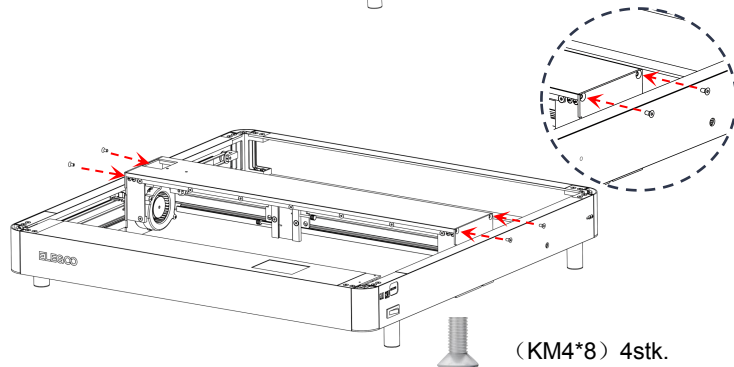
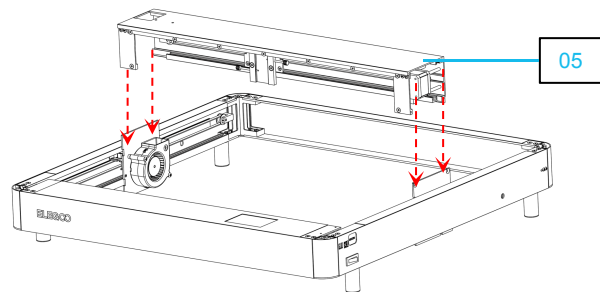

- Richten Sie die X-Achse an den verbleibenden Löchern an den seitlichen Blenden aus. Sobald sie ausgerichtet ist, ziehen Sie die Schrauben fest.

⑤

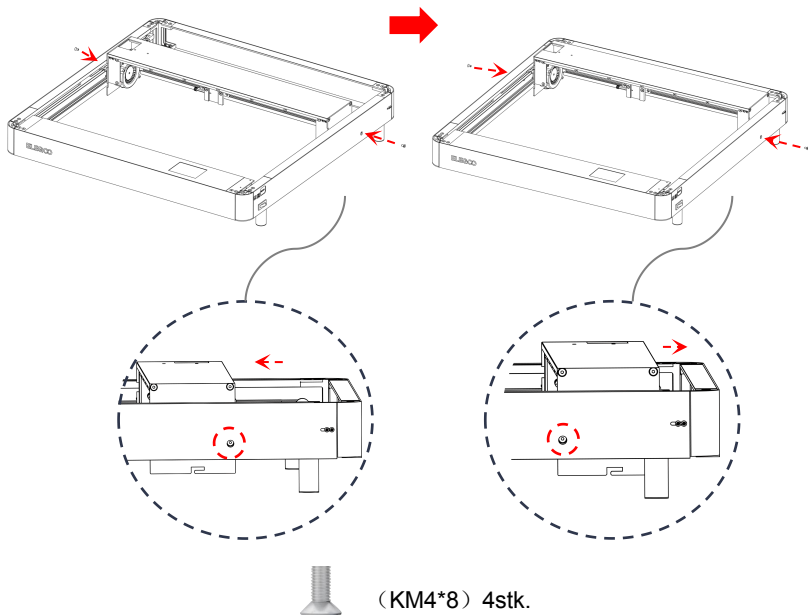

➤ Montage der X-Achsen-Einheit

⑥

- ① Bei der Installation die X-Achsen-Einheit gegen die vordere Blende ziehen. (X-Achse horizontal halten)
- ② Führen Sie das Synchronrad durch den Synchronriemen und befestigen Sie es am Lager.
- ③ Verbinden Sie die Kupplung mit der Motorwelle und ziehen Sie die Schrauben fest, um sie zu sichern. (Lösen Sie die Schrauben an der Kupplung vor der Installation.)

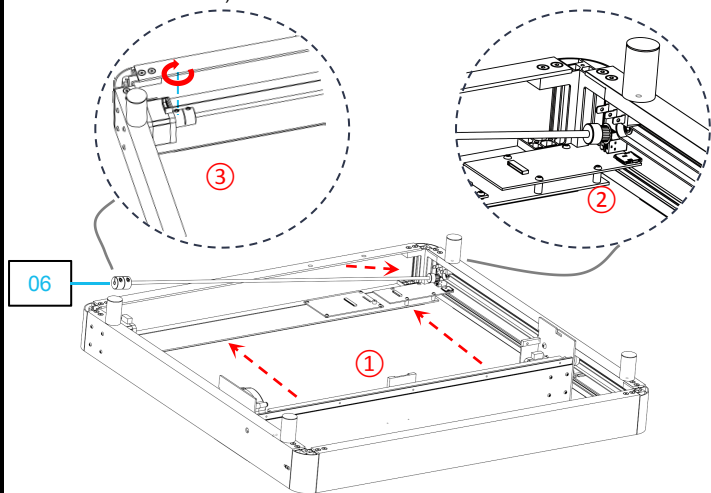

7

➤ **Timing Belt Installation:**

Install the timing belt with the tooth surface facing up into the slot.

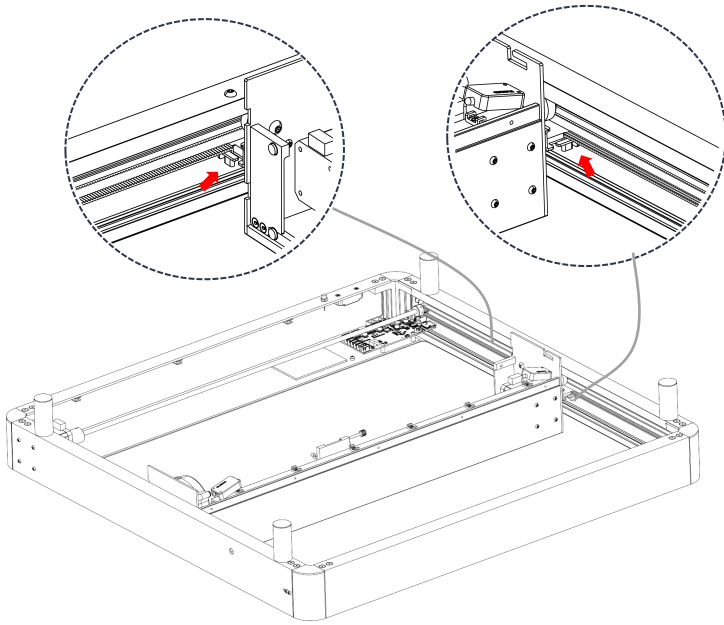

8

➤ **Timing Belt Adjustment:**

Loosen the side screws and tighten the adjustment slider of the timing belt towards one end. Then resecure the screws to lock it in place.

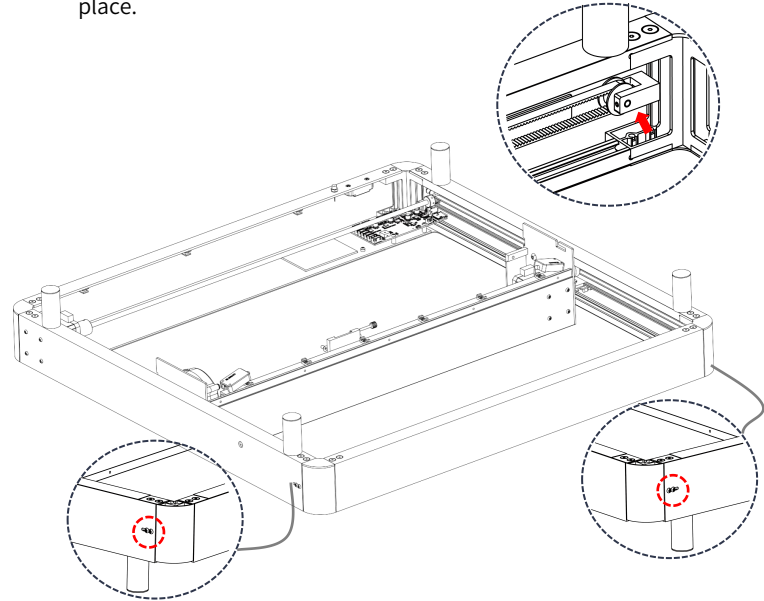

➤ Befestigen Sie die hintere Blende.

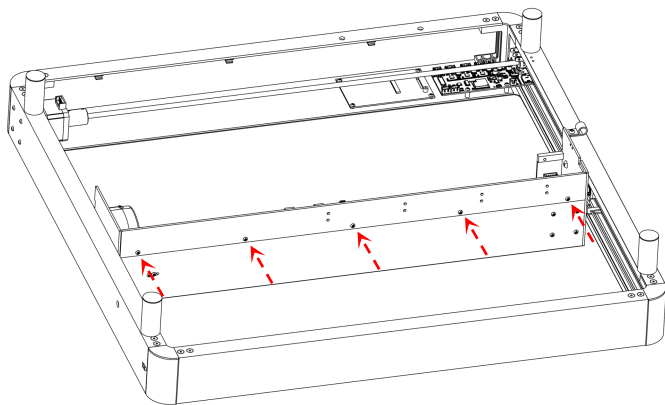

08



(PM3*6) 5stk.

9

➤ Verbinden Sie das Motherboard / Installieren Sie die Antenne.

➤ Verbinden Sie die Kabel gemäß der Kennzeichnungen mit den entsprechenden Anschlüssen

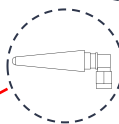
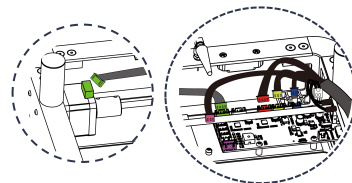
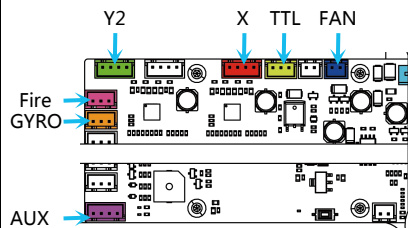

Antenne

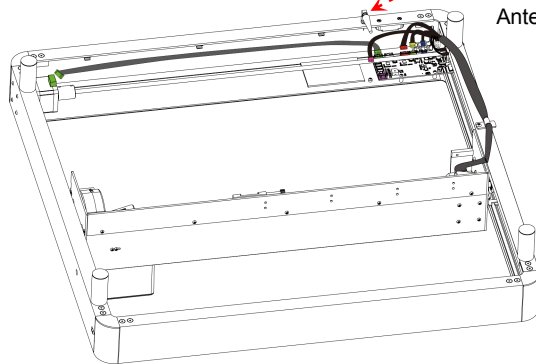

10

➤ Verkabelung der X-Achsen-Einheit

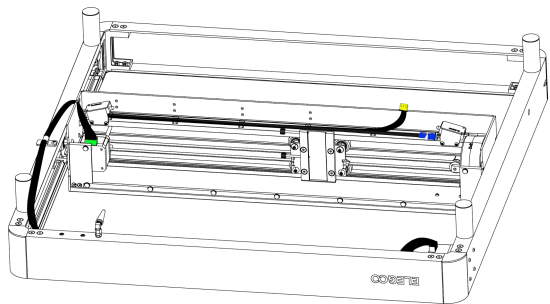

11

➤ Einstecken des Kabels

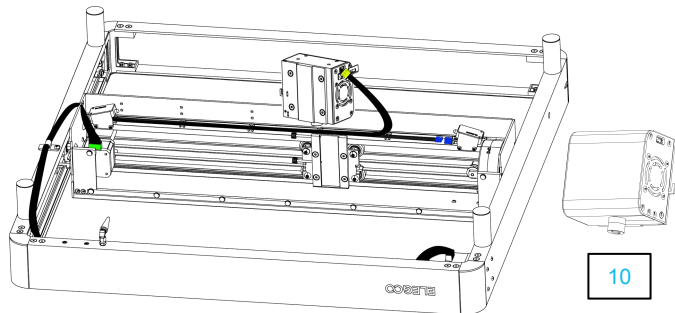

10

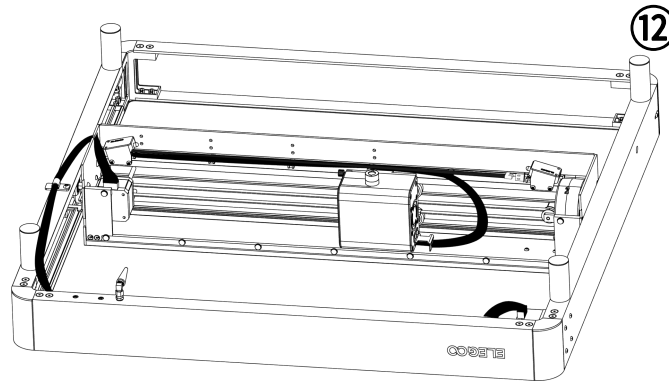

12

➤ Montage des Laserkopfs:

Führen Sie den Laserkopf entlang der Nut ein und ziehen Sie ihn mit den seitlichen Schrauben auf die vorgegebene Höhe fest.

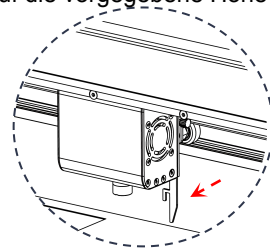
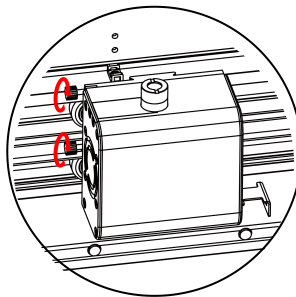

Ziehen Sie die Fokus-Positionierungsleiste heraus und ziehen die Schrauben an der Seite fest, um die Höhe einzustellen, an der die hervorstehende Positionierungsleiste das Graviermaterial berührt.

➤ Luftfilter Montage

13

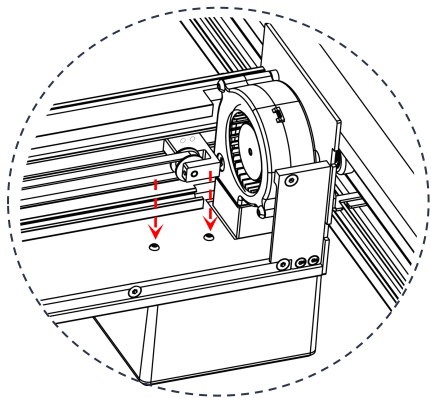

(PM3*6) 2stk.

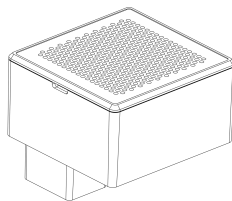

09

➤ Installation der vorderen Blenden und der abgerundeten Eckblenden.

14

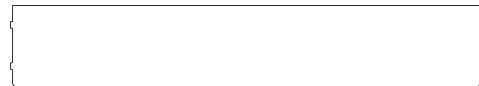
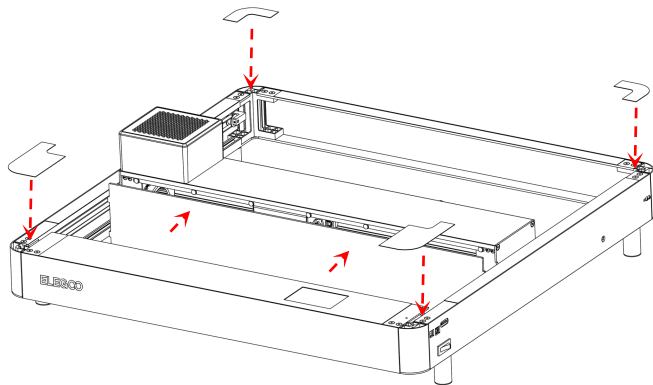

07



1stk.

1stk.

2stk.

Einführung in das Bedienfeld

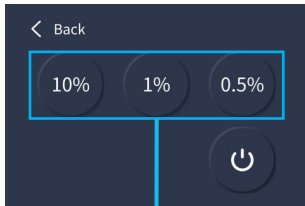
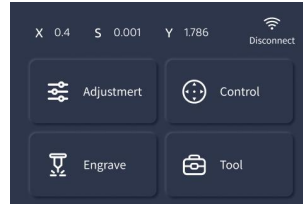

Einstellung der Laserleistung
(Dieser Leistungswert wird bei der
Positionierung verwendet)

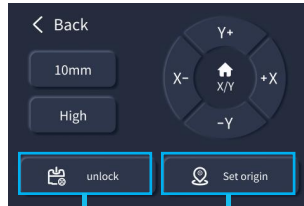

Entsperren der Motoren

Bewegen des Laserkopfs zur
angegebenen Position, um den
Ursprung zu lokalisieren.

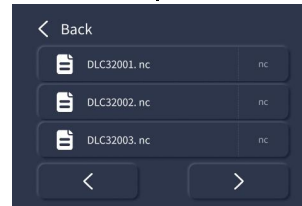

Wählen Sie die Datei aus, die
gravieren soll, bestimmen Sie
die Position durch Markieren des
Umfangs und setzen Sie dann den
Ursprung.

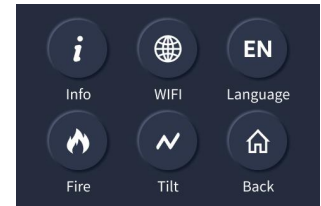

Inbetriebnahme

Dieses Gerät ist mit verschiedener Slicing-Software, wie z.B. LaserGRBL, LightBurn und PHECDA APP, kompatibel. Diese Bedienungsanleitung basiert auf der Open-Source-Software LaserGRBL.

1. Gravieren via TF-Karte: Speichern Sie die Datei über die Slicing-Software LaserGRBL auf der TF-Karte und wählen Sie die gewünschte Datei über das Bedienfeld zur Gravur aus.
2. Gravieren via USB: Verbinden Sie den Computer mit dem Gerät über das USB-Datenkabel und starten Sie die Gravur durch die LaserGRBL-Software.
3. Gravieren via App: Installieren Sie die PHECDA APP auf Ihrem Mobiltelefon, verbinden Sie Ihr Mobiltelefon mit dem WLAN des Geräts, geben Sie die IP-Adresse des Geräts in der App ein anschließend kann das Gerät, nach erfolgreicher Verbindung, gesteuert werden.

①

Gravieren via TF-Karte



Bild importieren



Wählen sie die Art der Gravur aus

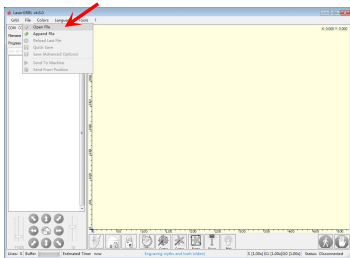
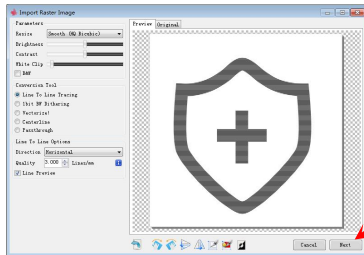
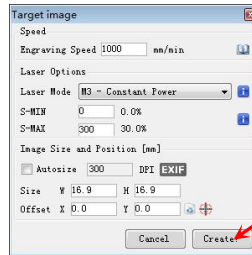

Passen Sie die Bildgröße und Laserparameter an.

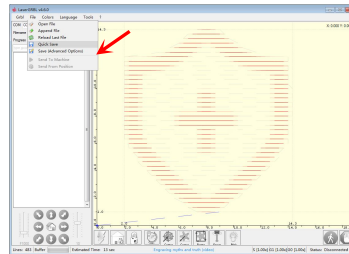
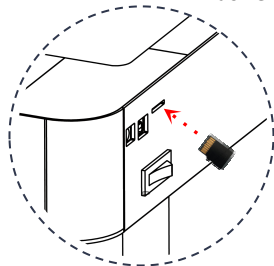

Speichern Sie die Slice-Datei auf der TF-Karte.

Platzieren Sie das zu gravierende Material

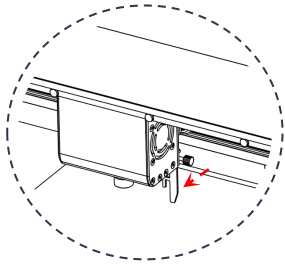
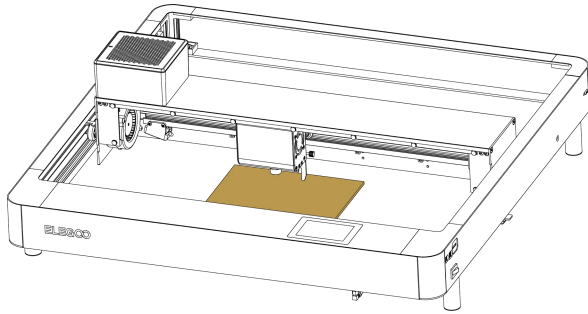

Ziehen Sie die Fokus-Positionierungsleiste heraus und ziehen die Schrauben an der Seite fest, um die Höhe einzustellen, an der die hervorstehende Positionierungsleiste das Graviermaterial berührt.

Klicken um
Graviervorgang
zu beginnen

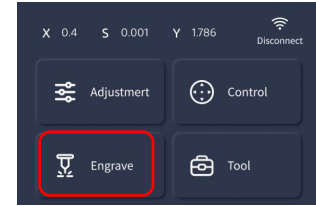

Zu gravierende
Datei auswählen

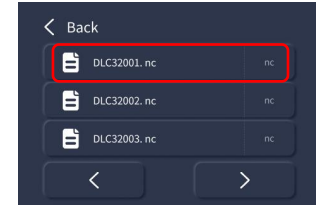

Wählen Sie den Ebenen-
Modus aus → Auswahlsatz
Ursprung → den Umkreis
markieren → bestätigen und
gravieren



Schalten Sie das Gerät ein, verbinden Sie es über USB mit dem Computer, öffnen Sie die Slicer-Software mit einem Doppelklick, klicken Sie auf die Schaltfläche "Verbinden", anschließend zeigt die Software an, dass die Verbindung erfolgreich war.
 (Hinweis: Sie können nicht gleichzeitig mehrere Slicer-Softwares öffnen, da es möglicherweise zu Konflikten kommt und das Gerät nicht verbunden werden kann.)

②
 Gravieren
 via USB

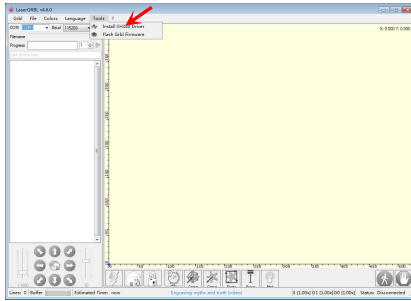

Falls keine Verbindung hergestellt werden kann, installieren Sie bitte den CH340 Treiber.

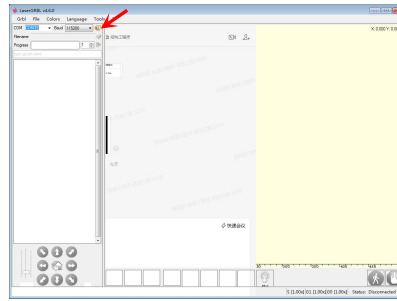

Klicken Sie auf
 Verbinden

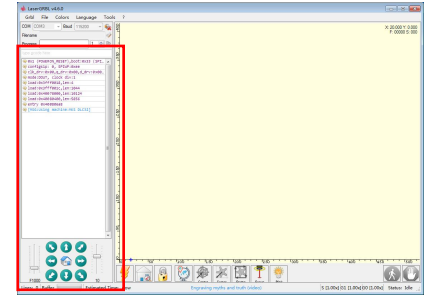

Die Verbindung ist erfolgreich, im linken Textfeld
 Daten angezeigt werden.

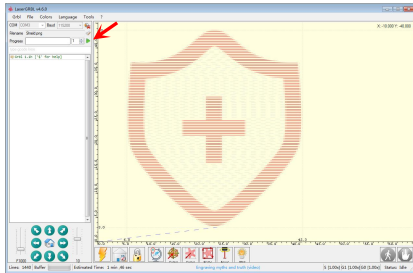

Starten Sie den slicing Vorgang

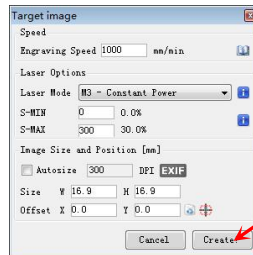

Passen Sie die Größe des Bildes und die
 Laserparameter an.

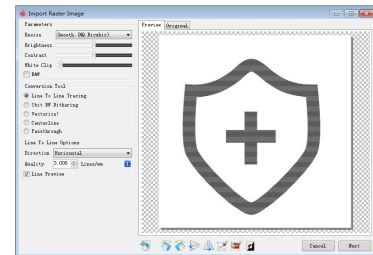

Zu gravierendes
 Bild importieren

Suchen Sie im App Store Ihres Mobilgeräts nach "PHECDA APP", um die App herunterzuladen und zu installieren.

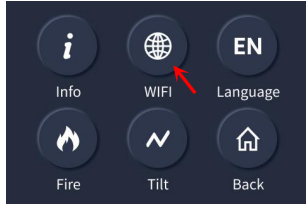

Klicken Sie auf die WLAN-Verbindung des Geräts.

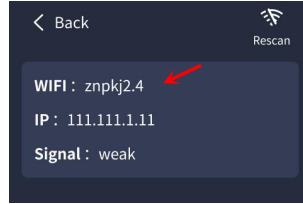

Klicken Sie auf Verbinden



Verbinden Sie Ihr Gerät mit dem WiFi-Netzwerk.
Standardmäßiges Passwort: 12345678.

3

Gravieren via App

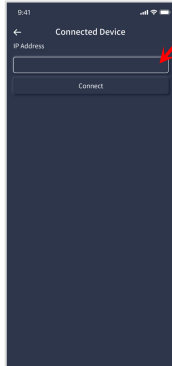

Geben Sie die IP-Adresse, welche auf dem Bedienfeld angezeigt wird und klicken Sie auf Verbinden

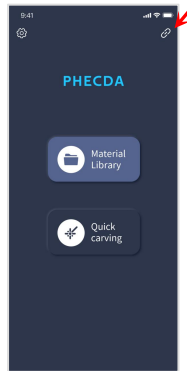

Öffnen Sie die PHECDA APP auf Ihrem Mobiltelefon die und klicken Sie auf die Schaltfläche, durch den Pfeil angezeigt wird.



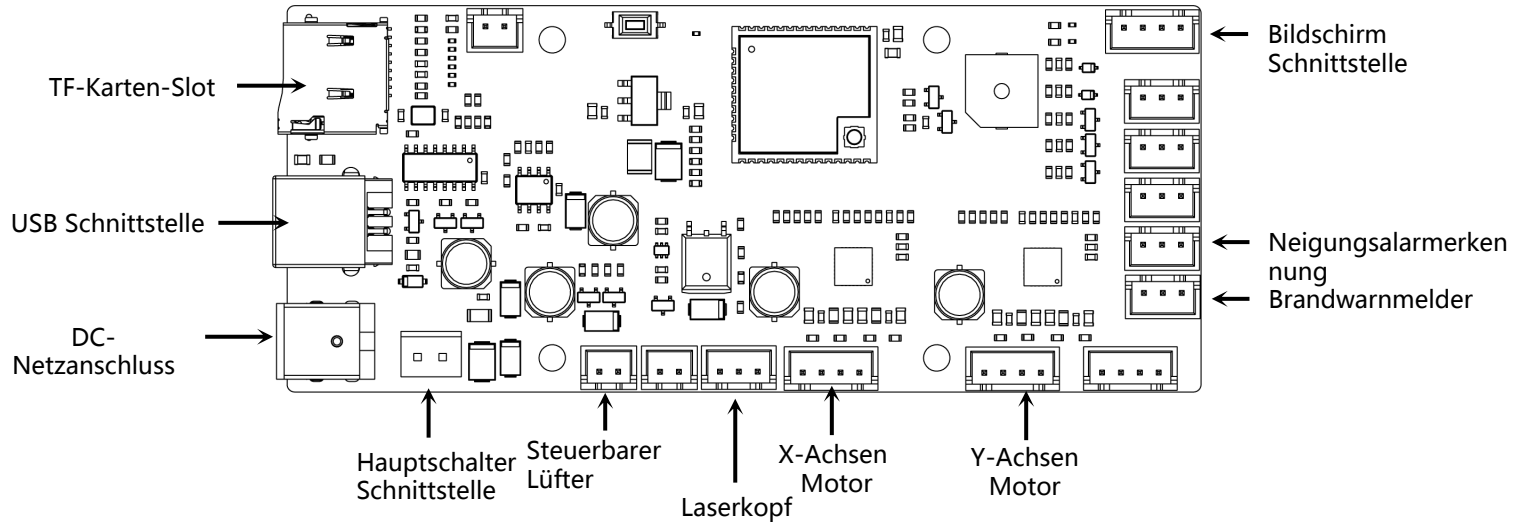

Hinweis: Wenn Sie die APP verwenden möchten, muss im Gerät eine TF-Karte, da sonst keine Dateien hochgeladen werden können.

Motherboard Wiring

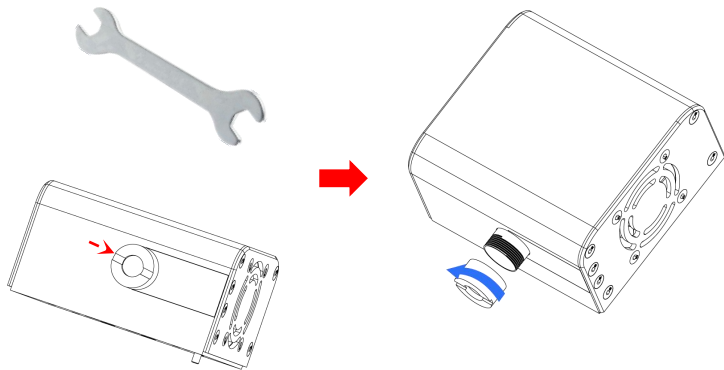

Wartungshinweise

- Nach längerer Nutzung sollte der Spiegel des Laserkopfes regelmäßig gereinigt werden. Durch Rauchablagerungen kann nach langem Schneiden und Gravieren die Laserleistung verschlechtert werden. (Den Spiegel mit Ethanol($\geq 75\%$) reinigen)
- So entfernen Sie den Spiegel:
Setzen Sie den Schraubenschlüsselgriff in die Nut ein und schrauben Sie den Spiegel heraus.



Air assist installation (optional)

➤ Stückliste

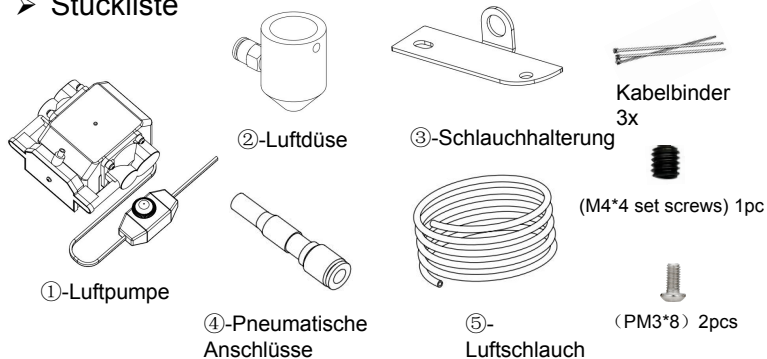

➤ Montage

Entfernen Sie die beiden Schrauben auf der unteren linken Seite des Laserkopfes

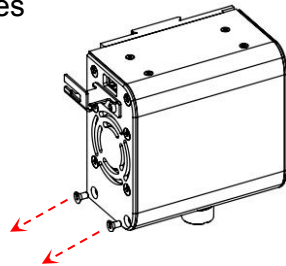

- Montieren Sie die Schlauchhalterung

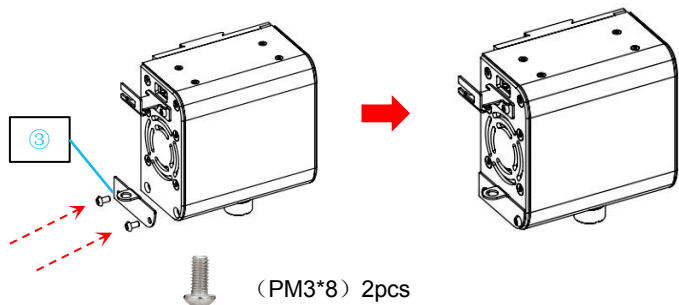

- Montieren Sie die Luftdüse

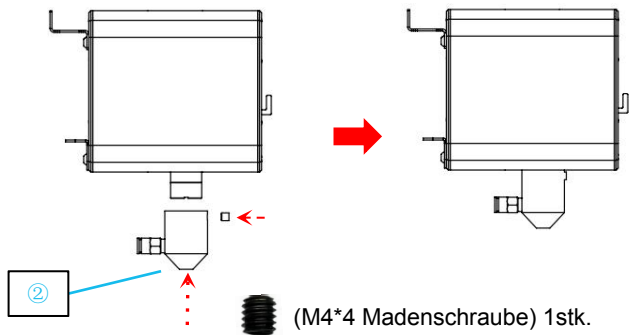

- Stecken Sie den Luftschauch auf den dafür vorgesehenen Anschluss

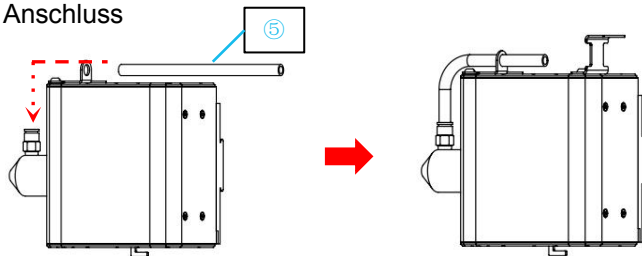

- Stecken Sie den Luftschauch auf die Luftpumpe

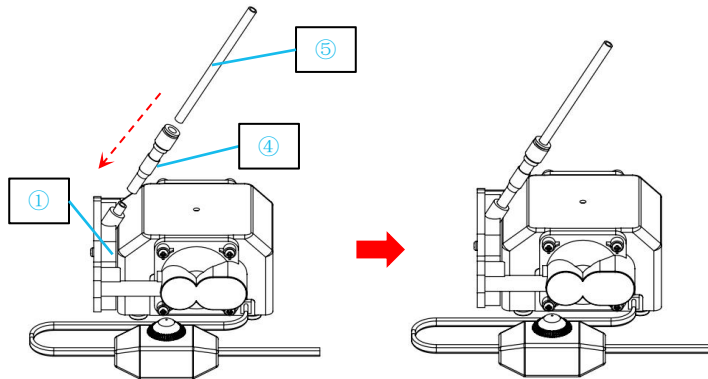

Verwenden Sie einen Kabelbinder, um den Luftschauch und das Lasergerätekabel zusammen zu befestigen, um zu verhindern, dass der Luftschauch während des Gebrauchs beschädigt wird.

After-sales service registration card
售后服务登记卡

Date of purchase

购买日期： _____

Place of purchase

购买地点： _____

Printer

机器： _____

S/N

序列号： _____

Fault description

故障描述： _____

Contact

联系人： _____

Phone number

电话号码： _____

Address

地址： _____



ELEGOO official website: www.elegoo.com

